

TEMA 9 Cicloconvertidores

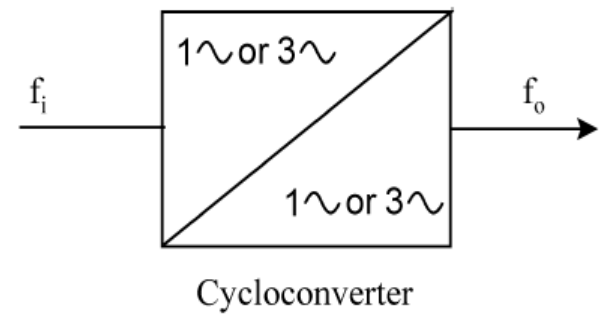

$$\alpha 1 + \alpha 2 = \pi$$

$$v' = U_{do} \cdot \cos(\alpha 1) = -U_{do} \cdot \cos(\alpha 2)$$

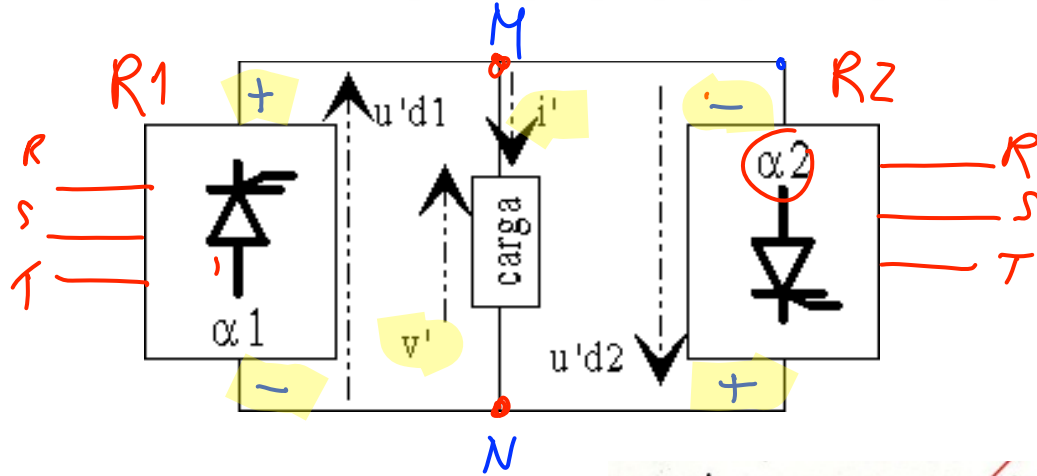
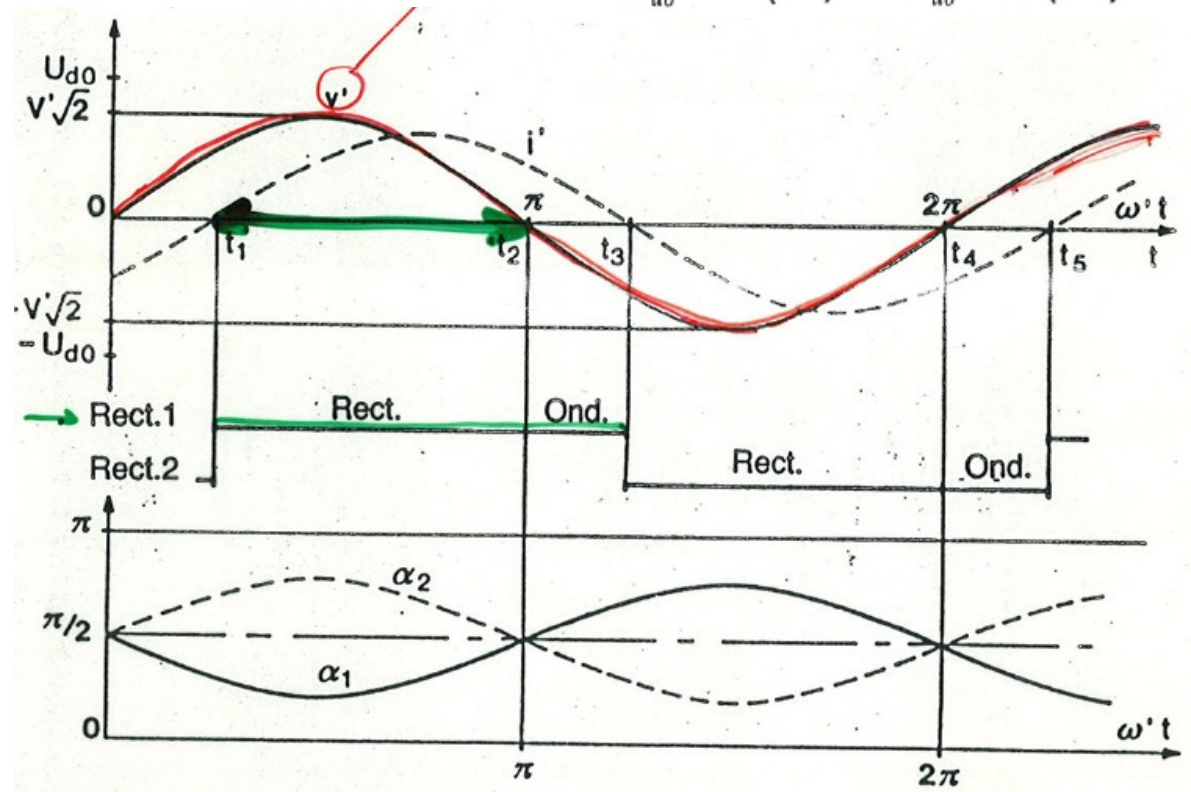

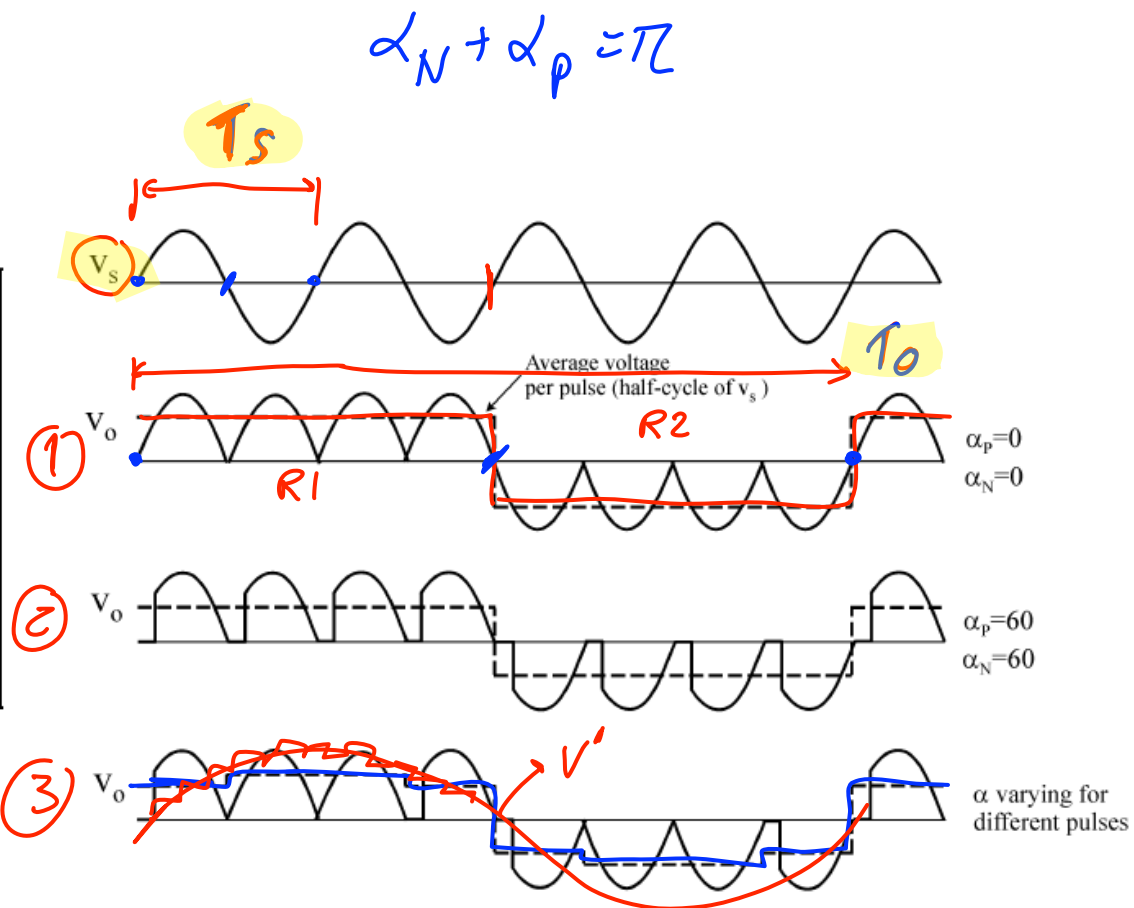
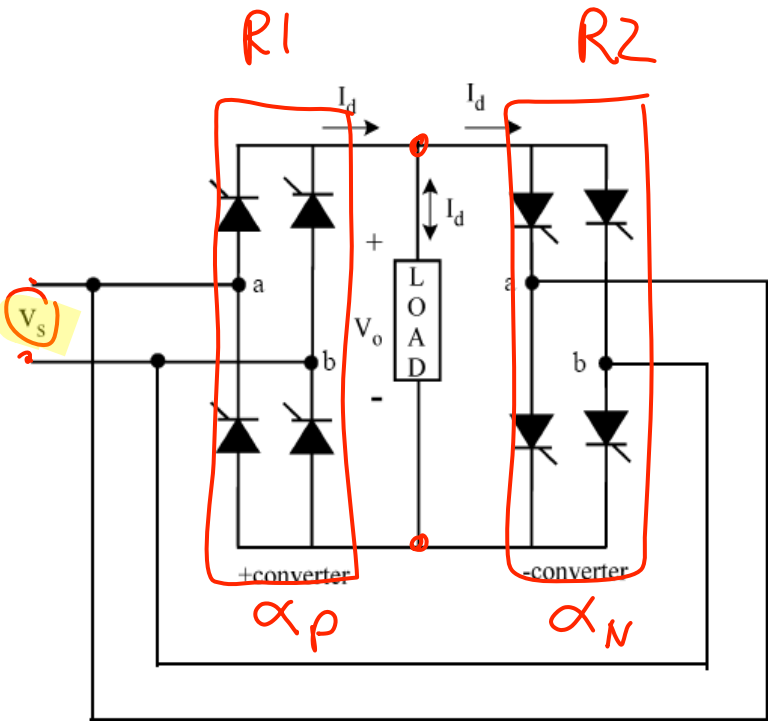
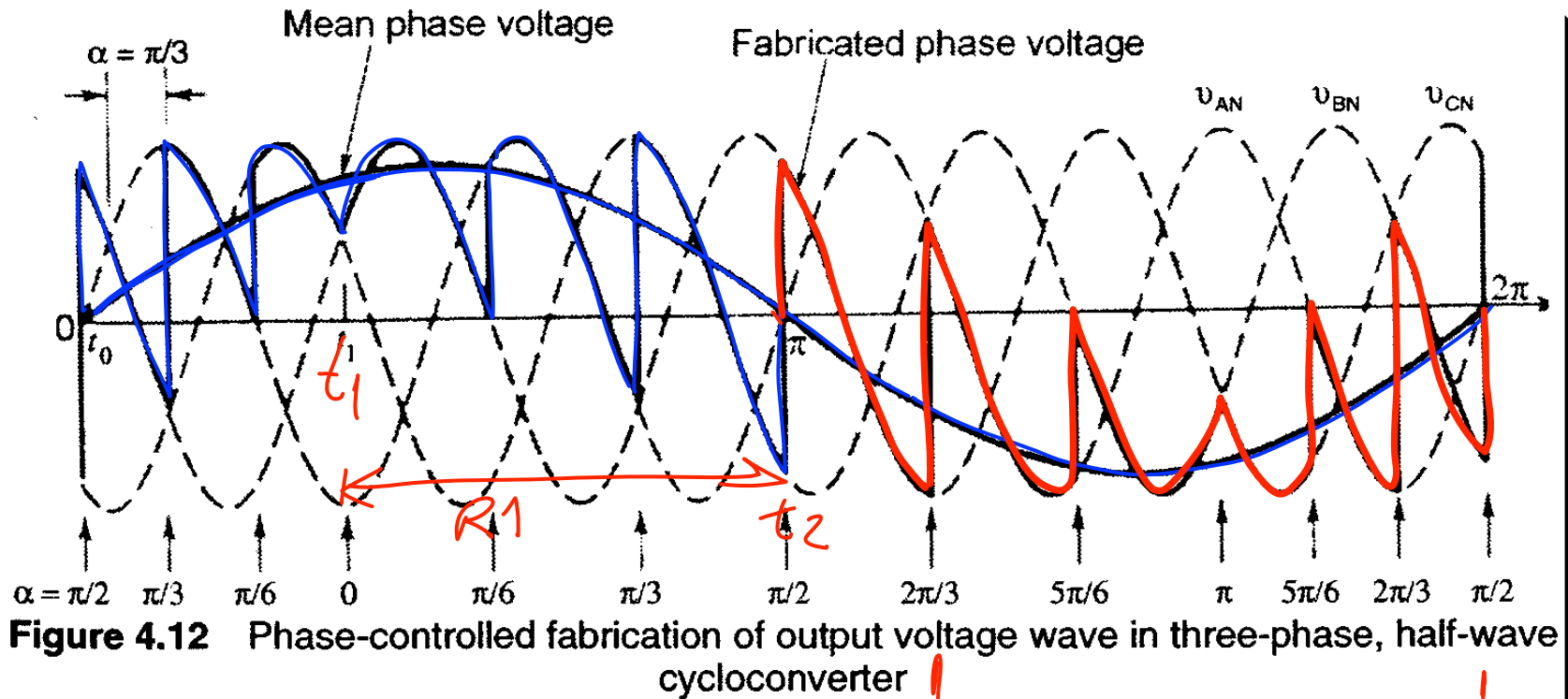

Fig. 2 Single-phase to single-phase cycloconverter

* Functio. sin corriente de circulaci3n entre los rectificadores

• $f_o = \frac{f_i}{4}$ • $H_n \uparrow$

La tensión de salida se obtiene gracias a una modulación sinusoidal de los ángulos de disparo de las tiristores



El valor medio de la tensión de salida suministrada por el conjunto de los dos rectificadores en antiparalelo puede resultar **con una componente alterna distinta de cero**, si modulamos de forma periódica sus ángulos de control.

Así para obtener una salida v' senoidal, de frecuencia angular ω' y de amplitud $V'\sqrt{2}$, se deben de variar los ángulos de control α_1 y α_2 para obtener:

$$\alpha_1 + \alpha_2 = \pi$$

$$v' = U_{do} \cdot \cos(\alpha_1) = -U_{do} \cdot \cos(\alpha_2)$$

$v'(w't)$

$$U_{do} \cdot \cos(\alpha_1) = -U_{do} \cdot \cos(\alpha_2) = V'\sqrt{2} \cdot \text{sen}(w't)$$

$$\alpha_2(t) = \pi - \alpha_1(t) = \pi - \arccos\left(\frac{V'\sqrt{2} \cdot \text{sen}(w't)}{U_{do}}\right)$$

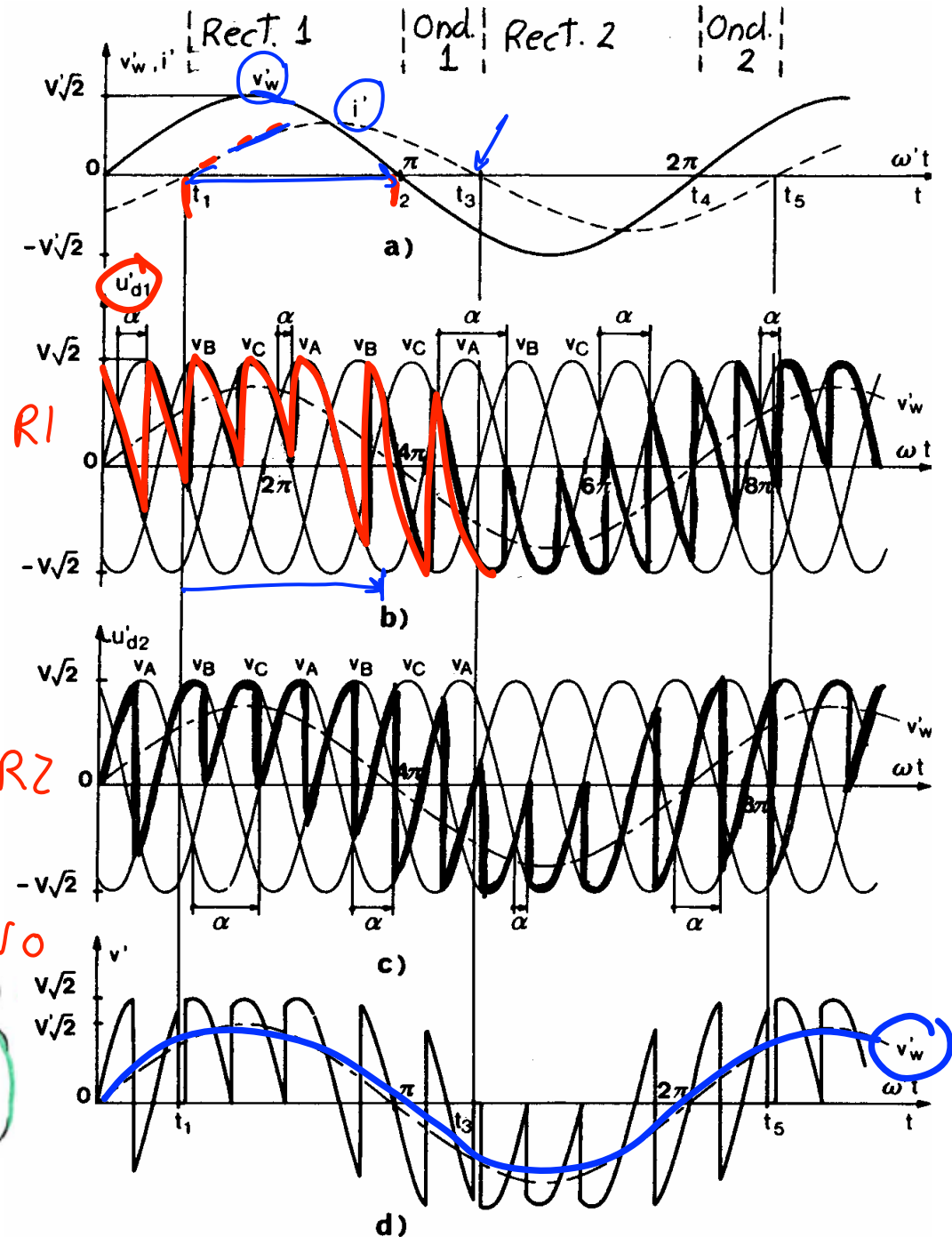

el inconveniente de este ejemplo sencillo, reside en el **elevado nivel de armónicos de la tensión** en bornes de la carga.

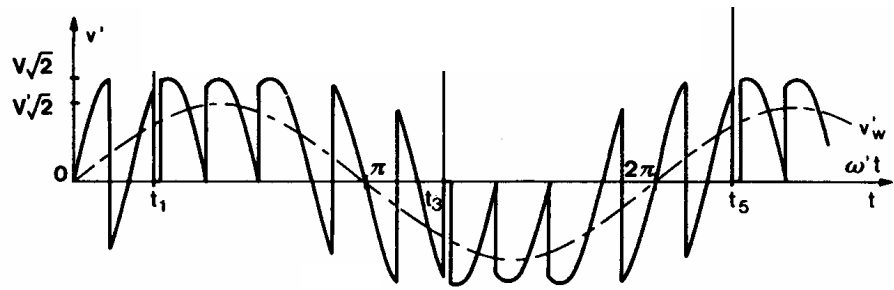
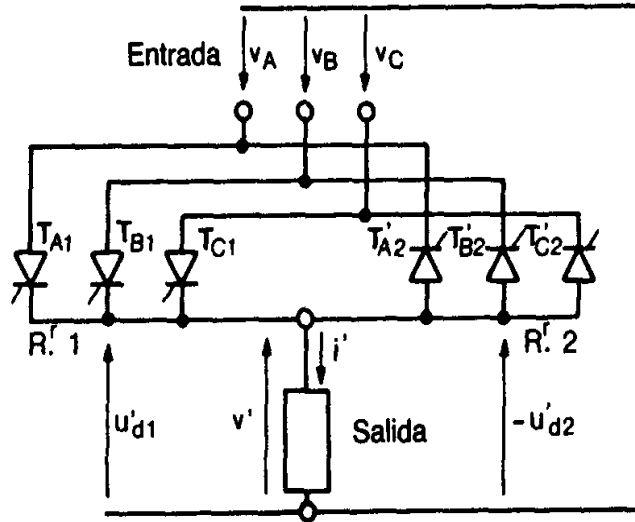

$p=3$

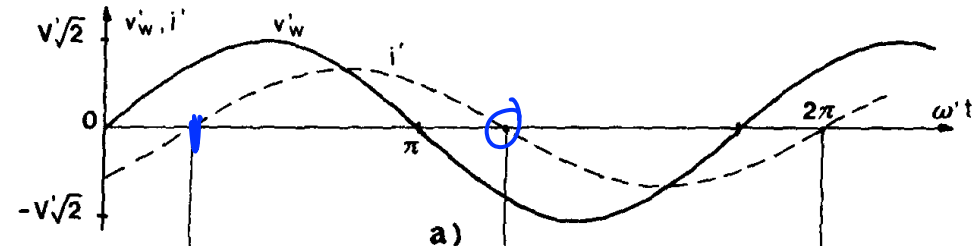

$p=6$

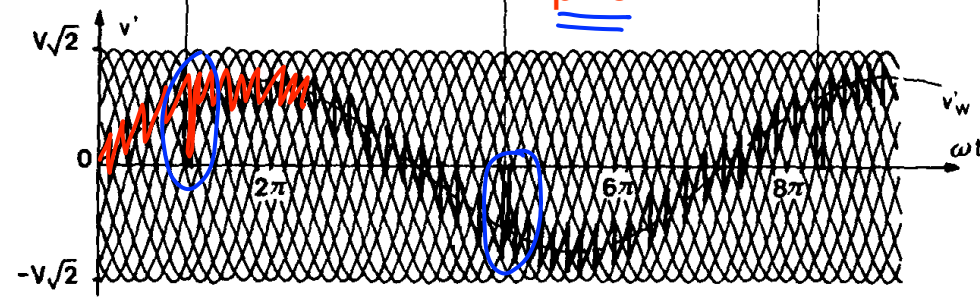

$p=12$

Montajes utilizados

monofásico-monofásico

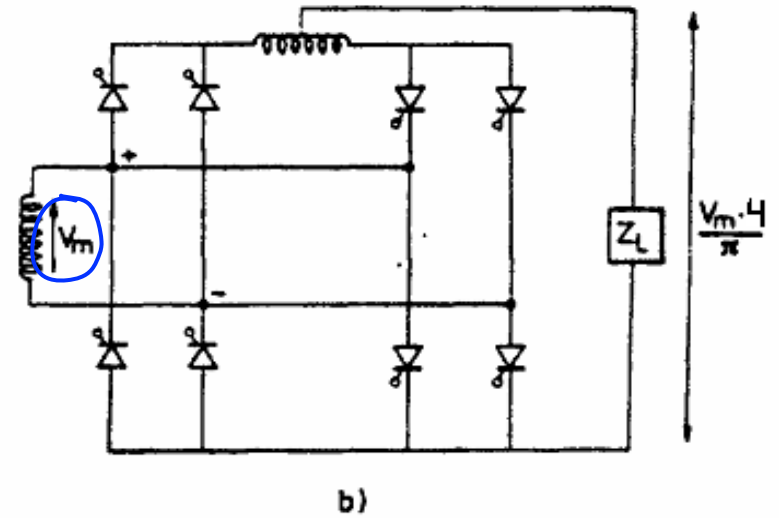
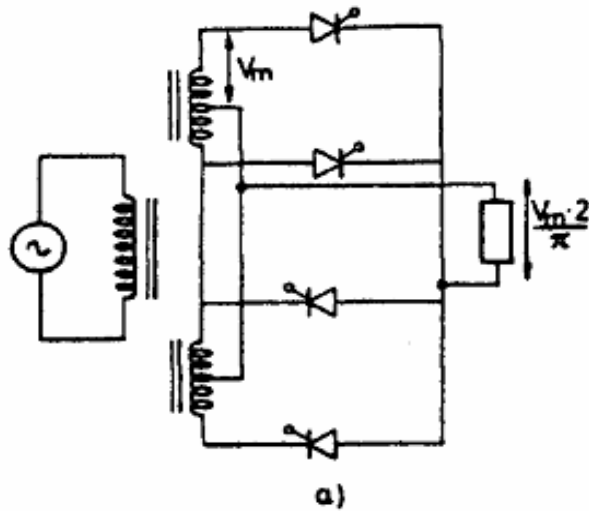

trifásico-monofásico

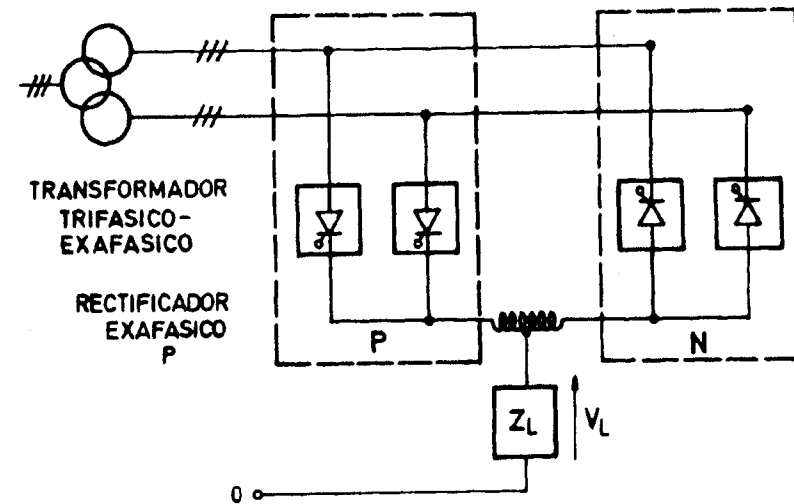
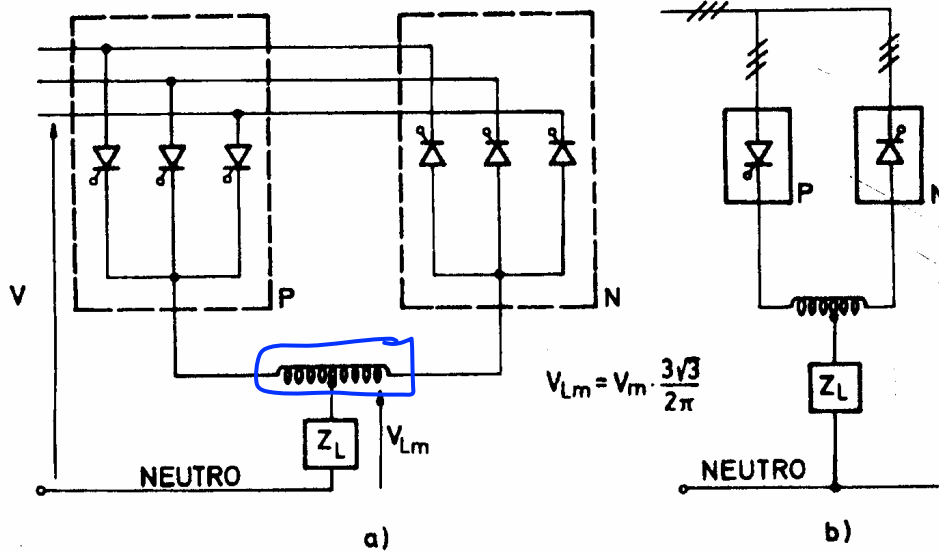

trifásico-trifásico

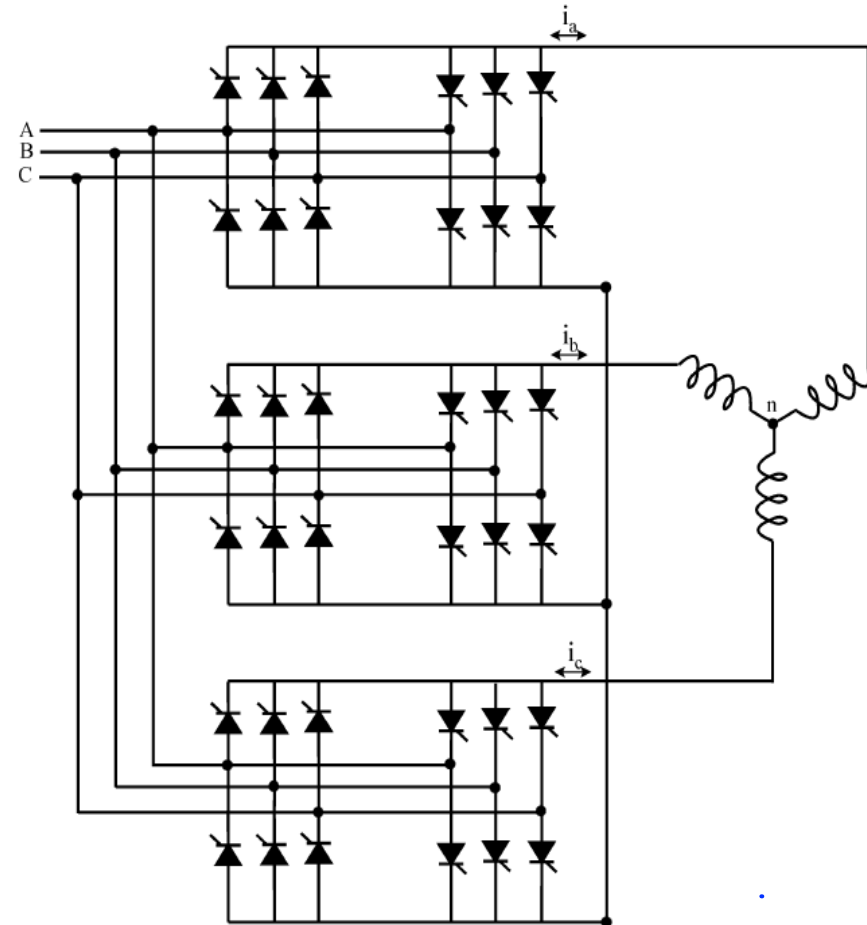
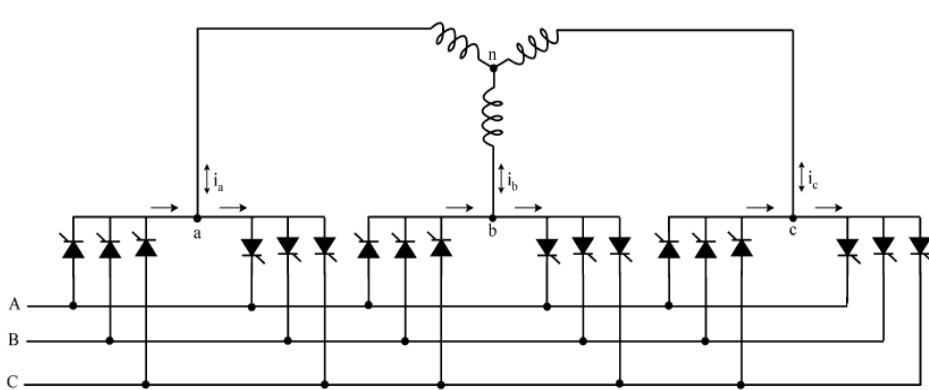
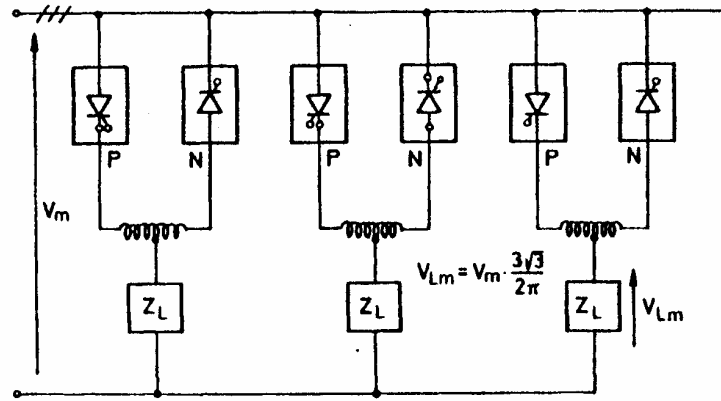

Aplicaciones

Motores de Inducción y motores síncronos de baja velocidad y alta potencia (multi-MW)

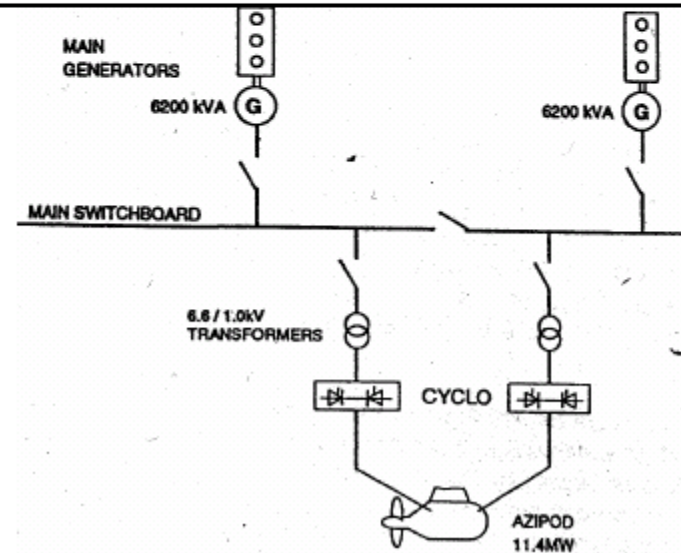
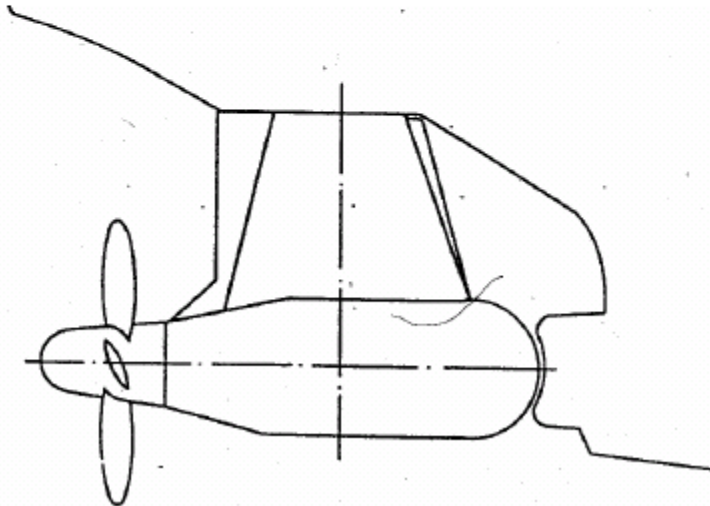
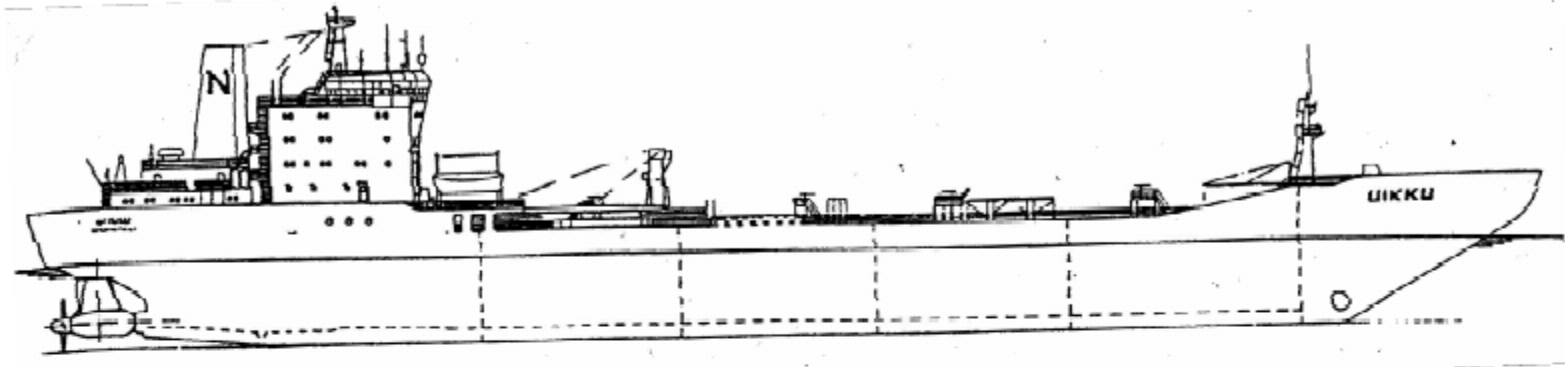

Aplicaciones

Motores de Inducción y motores síncronos de baja velocidad y alta potencia (multi-MW)

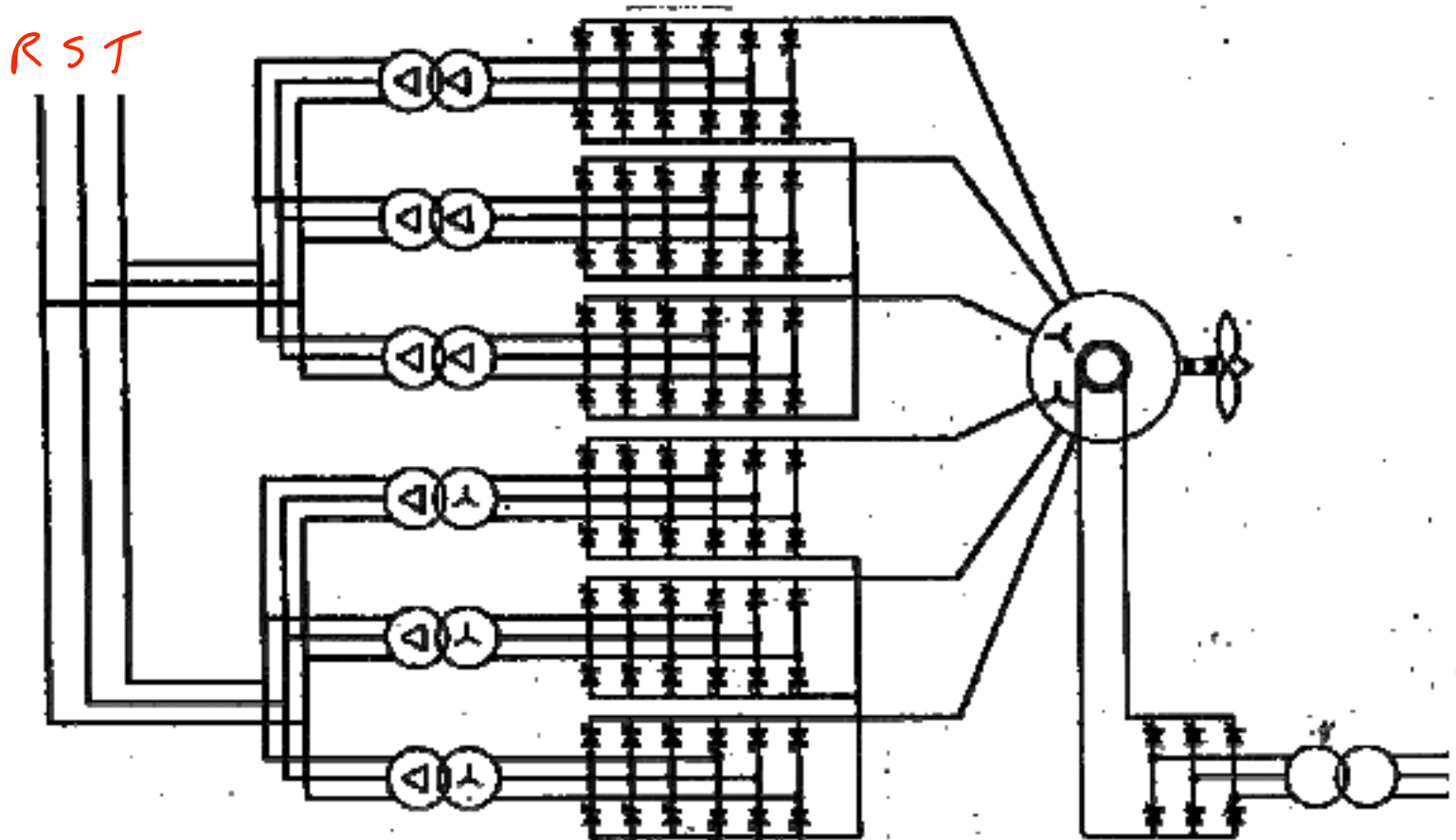

Aplicaciones

Icebreaker example:

- twin shafts each rated at 11.2 MW,
- each shaft being powered by two 5.6 MW Cycloconverters capable of providing 175% full load torque (FLT) for 30 seconds at zero speed.

