

## Práctica 8. Lectura/escritura de un medidor de temperatura con interfaz SPI.

### 1. Introducción.

En esta sesión se va a realizar un diseño capaz de comunicarse con un dispositivo mediante el interfaz serie estándar SPI. En este caso, la placa de pruebas con la FPGA Virtex-E incluye un termómetro digital DS1722 del fabricante Dallas Semiconductor nombrado como U9 situado al lado de los pulsadores SW1 y SW2 de la placa de FPGA.

Este dispositivo permite ser programado de diversos modos, pudiendo incluso comunicarse con los dispositivos mediante el interfaz SPI ó el estándar “3-wire”. En este caso trabajaremos exclusivamente con el estándar SPI.

Por otro lado, el termómetro permite ser configurado para enviar lecturas continuas conforme se va obteniendo la medida, o bien enviar una lectura sólo cuando ésta sea solicitada. La precisión de la lectura también puede ser configurada, siendo posible configurarla entre 8 y 12 bits (precisiones de 1°C a 0,0625°C), con un rango de medida entre -55°C y 120°C. La salida digital proporcionada está en formato de complemento a dos, ya que se aplican números positivos y negativos.

El dispositivo DS1722 posee tres registros:

- Registro de configuración. Con dirección 00h para lectura y 80h para escritura. Aquí se configura la selección de conversión continua o discontinua y la resolución de bits deseada.
- Registro de lectura de bits menos significativos (LSB). Con dirección 01h, donde se leen los bits del 8 al 11 en caso de tener resolución mayor de 8 bits. Estos bits proporcionan el valor decimal de la temperatura.
- Registro de lectura de bits más significativos (MSB). Con dirección 02h, donde se leen los bits del 0 al 7 para leer el valor de la temperatura. Estos bits ofrecen el valor entero de la temperatura.

Para más detalles, consultar la hoja de especificaciones que se incluye al final del guión de prácticas.

### 2. Objetivo de la práctica.

El objetivo de la práctica es la visualización en los dos display de 7 segmentos de la medida de temperatura proporcionada por el termómetro DS1722.

Para simplificar el funcionamiento, el dispositivo se va a configurar para realizar medidas de temperatura continuadas con 8 bits de resolución, por lo que el modo básico de funcionar es el siguiente:

- Primero pulsando la señal “*escribeconfig*” se configura el registro 80h con la palabra 00h para tener 8 bits de resolución y lecturas continuas. Para realizar este proceso, se escriben los 16 bits seguidos en la línea SDI, en primer lugar la dirección (80h), seguido de los datos (00h).
- En segundo lugar se realiza una consulta continuada del registro 02h para conocer el valor que contiene y mostrarlo en el display. El valor a mostrar en el display será siempre el valor absoluto, de modo que si es un número negativo éste se indicará iluminando los LED de punto decimal junto con la medida correspondiente. Para realizar este proceso, primero se escriben los 8 bits de dirección (02h) en la línea SDI, y seguidamente se leen los 8 bits de datos que el DS1722 pone en la línea SDO, y que corresponden con el valor de la temperatura.

Estamos hablando todo el rato de escribir y leer valores de 8 bits, en cambio, hay que tener en cuenta que estos valores es necesario escribirlos/leerlos en serie, es decir uno tras otro sobre la misma línea de salida/entrada. Para ello, de forma detallada se describe el proceso en la hoja de especificaciones del fabricante, pero de forma resumida vamos a describir el procedimiento a seguir:

El DS1722 posee las siguientes líneas de comunicación:

Línea CE (Chip Enable): cualquier comunicación es necesario hacerla con CE='1', en otro caso los valores de las líneas de datos no son relevantes. Es controlada por la FPGA.

Línea SCLK (Reloj): Es la responsable de generar los sincronismos capaces de indicar el paso de un bit a otro (dónde termina uno y comienza otro) en las líneas SDI y SDO. Está controlada por la FPGA. La frecuencia **máxima** a la que puede oscilar este reloj es de 5MHz. El reloj sólo debe ser activado cuando CE esté activo. El flanco en el que se deben captar los datos es el que corresponde al segundo flanco que se genere después de la activación de CE, es decir, si tras activar CE, SCLK comienza de nivel bajo a alto, el

segundo flanco es de bajada, siendo éste donde se debe recoger el valor de la línea, asegurando de este modo que el dato es válido.

Línea SDI (Data input): Es la línea de datos serie por la que se escriben valores en el DS1722.

Línea SDO (Data Output): Es la línea de datos serie por la que se leen los valores del DS1722.



Figura que muestra las líneas externas (así como si son de Entrada o Salida) de la FPGA a diseñar.

La entrada del reloj principal del sistema es un oscilador a 40MHz. La entrada de Reset hace que el sistema ponga a cero la salida de visualización y anule cualquier proceso de lectura/escritura que se pudiera estar llevando a cabo.

## 2.1. Pasos a seguir.

Los pasos a seguir son los siguientes:

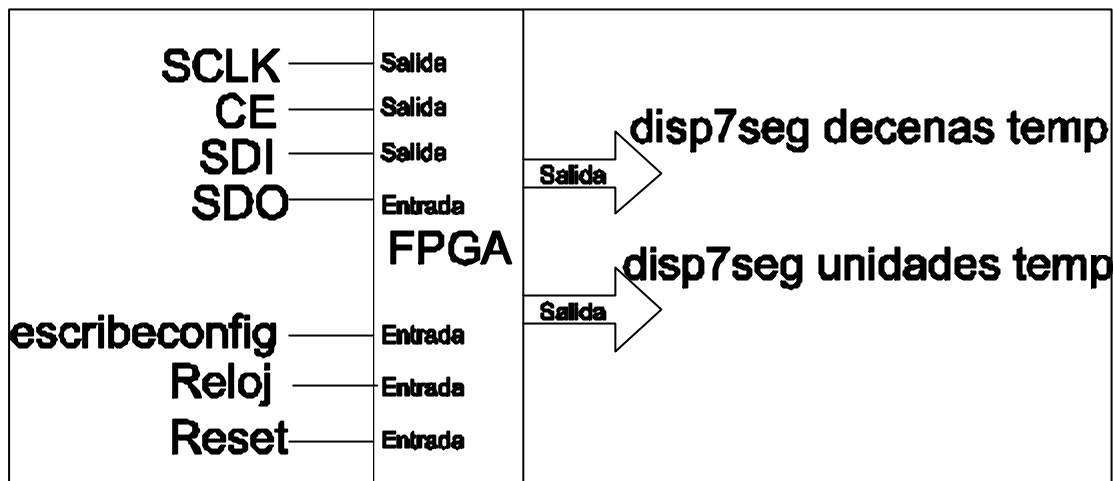
1. Diseñar el sistema y realizar una simulación sencilla mediante un banco de pruebas con estímulos predefinidos, ya sea mediante "HDL bencher" o fichero de estímulos propio.
2. Una vez ha sido correctamente simulado, implementar el sistema para el dispositivo VirtexE usado en prácticas anteriores. La asignación de patillas debe consultar en la hoja de especificaciones de la placa de pruebas.
3. Comprobar el funcionamiento sobre la placa.

## 3. Documentación a entregar.

En las dos semanas siguientes a la realización de la práctica, se entregará un pequeño dossier que incluya la descripción del proceso de diseño, el código VHDL del diseño propuesto, los resultados de la simulación (ficheros), los resultados de la implementación (lógica necesaria, es decir, CLB ocupados, etc.), así como la opinión personal acerca de la práctica realizada y dificultades encontradas en el desarrollo de la misma.

### FEATURES

- Temperature Measurements Require No External Components
- Measures Temperatures from -55°C to +120°C. Fahrenheit Equivalent is -67°F to +248°F
- Thermometer Accuracy is  $\pm 2.0^{\circ}\text{C}$
- Thermometer Resolution is Configurable from 8 to 12 bits (1.0°C to 0.0625°C Resolution)
- Data is Read From/Written to Via a Motorola Serial Peripheral Interface (SPI) or Standard 3-Wire Serial Interface
- Wide Analog Power Supply Range (2.65V - 5.5V)
- Separate Digital Supply Allows for 1.8V Logic
- Available in an 8-Pin SO (150mil), 8-Pin  $\mu\text{MAX}$ , and Flip-Chip Package

### PIN ASSIGNMENT

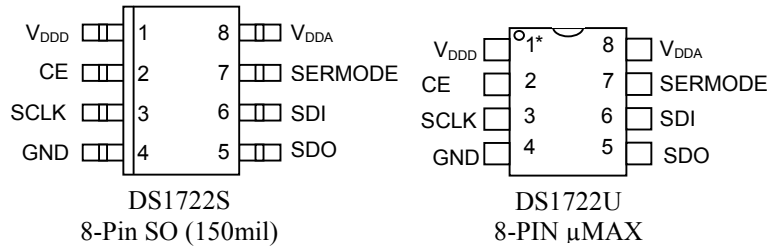

### PIN DESCRIPTION

- |                  |                          |
|------------------|--------------------------|
| SERMODE          | - Serial Interface Mode  |
| CE               | - Chip Enable            |
| SCLK             | - Serial Clock           |
| GND              | - Ground                 |
| $V_{\text{DDA}}$ | - Analog Supply Voltage  |
| SDO              | - Serial Data Out        |
| SDI              | - Serial Data In         |
| $V_{\text{DD}}$  | - Digital Supply Voltage |

### DESCRIPTION

The DS1722 Digital Thermometer and Thermostat with SPI/3-Wire Interface provides temperature readings which indicate the temperature of the device. No additional components are required; the device is truly a temperature-to-digital converter. Temperature readings are communicated from the DS1722 over a Motorola SPI interface or a standard 3-wire serial interface. The choice of interface standard is selectable by the user.

For applications that require greater temperature resolution, the user can adjust the readout resolution from 8 to 12 bits. This is particularly useful in applications where thermal runaway conditions must be detected quickly.

For application flexibility, the DS1722 features a wide analog supply rail of 2.65V - 5.5V. A separate digital supply allows a range of 1.8V to 5.5V.

The DS1722 is available in an 8-pin SO (150mil), 8-pin  $\mu\text{MAX}$ , and flip-chip package.

Applications for the DS1722 include personal computers/servers/workstations, cellular telephones, office equipment, or any thermally-sensitive system.

**ORDERING INFORMATION Table 1**

PART	MARKING	DESCRIPTION
DS1722S	DS1722	DS1722 in 150mil 8-Pin SO
DS1722S/T&R	DS1722	DS1722 in 150mil 8-Pin SO, Tape-and-Reel
DS1722U	1722	DS1722 in 8-Pin $\mu$ MAX
DS1722U/T&R	1722	DS1722 in 8-Pin $\mu$ MAX, Tape-and-Reel
DS1722U+	1722 (see note)	DS1722 in Lead-Free 8-Pin $\mu$ MAX
DS1722U+T&R	1722 (see note)	DS1722 in Lead-Free 8-Pin $\mu$ MAX, Tape-and-Reel
DS1722X/T&R	TO	DS1722 in Flip-Chip Package, Tape-and-Reel

Note: A “+” will also be marked on the package next to the pin 1 indicator.

Contact your Maxim sales representative for availability of other lead-free package options.

**DETAILED PIN DESCRIPTION Table 2**

SOIC	SYMBOL	DESCRIPTION
<b>PIN 1</b>	$V_{DDD}$	<b>Digital Supply Voltage</b> 1.8V-5.5V. Defines the top rails for the digital inputs and outputs.
<b>PIN 2</b>	CE	<b>Chip Enable</b> Must be asserted high for communication to take place for either the SPI or 3-wire interface.
<b>PIN 3</b>	SCLK	<b>Serial Clock Input</b> Used to synchronize data movement on the serial interface for either the SPI or 3-wire interface.
<b>PIN 4</b>	GND	<b>Ground pin.</b>
<b>PIN 5</b>	SDO	<b>Serial Data Output</b> When SPI communication is selected, the SDO pin is the serial data output for the SPI bus. When 3-wire communication is selected, this pin must be tied to the SDI pin (the SDI and SDO pins function as a single I/O pin when tied together.)
<b>PIN 6</b>	SDI	<b>Serial Data Input</b> When SPI communication is selected, the SDI pin is the serial data input for the SPI bus. When 3-wire communication is selected, this pin must be tied to the SDO pin (the SDI and SDO pins function as a single I/O pin when tied together.)
<b>PIN 7</b>	SERMODE	<b>Serial Interface Mode Input</b> This pin selects which interface standard will be used: SPI when connected to $V_{CC}$ ; standard 3-wire when connected to GND.
<b>PIN 8</b>	$V_{DDA}$	<b>Analog Supply Voltage</b> 2.65V – 5.5V input power pin.

**OVERVIEW**

A block diagram of the DS1722 is shown in Figure 1. The DS1722 consists of four major components:

1. Precision temperature sensor
2. Analog-to-digital converter
3. SPI/3-wire interface electronics
4. Data registers

The factory-calibrated temperature sensor requires no external components. The DS1722 is in a power-conserving shutdown state upon power-up. After power-up, the user may alter the configuration register to place the device in a continuous temperature conversion mode or in a one-shot conversion mode. In

the continuous conversion mode, the DS1722 continuously converts the temperature and stores the result in the temperature register. As conversions are performed in the background, reading the temperature register does not affect the conversion in progress. In the one-shot temperature conversion mode, the DS1722 will perform one temperature conversion, store the result in the temperature register, and then return to the shutdown state. This conversion mode is ideal for power sensitive applications. More information on the configuration register is contained in the "OPERATION-Programming" section.

The temperature conversion results will have a default resolution of 9 bits. In applications where small incremental temperature changes are critical, the user can change the conversion resolution from 9 bits to 8, 10, 11, or 12. This is accomplished by programming the configuration register. Each additional bit of resolution approximately doubles the conversion time.

The DS1722 can communicate using either a Motorola Serial Peripheral Interface (SPI) or standard 3-wire interface. The user can select either communication standard through the SERMODE pin, tying it to  $V_{DD3}$  for SPI and to ground for 3-wire.

The device contains both an analog supply voltage and a digital supply voltage ( $V_{DDA}$  and  $V_{DDD}$ , respectively). The analog supply powers the device for operation while the digital supply provides the top rails for the digital inputs and outputs. The DS1722 was designed to be 1.8V Logic-Ready.

## DS1722 FUNCTIONAL BLOCK DIAGRAM Figure 1

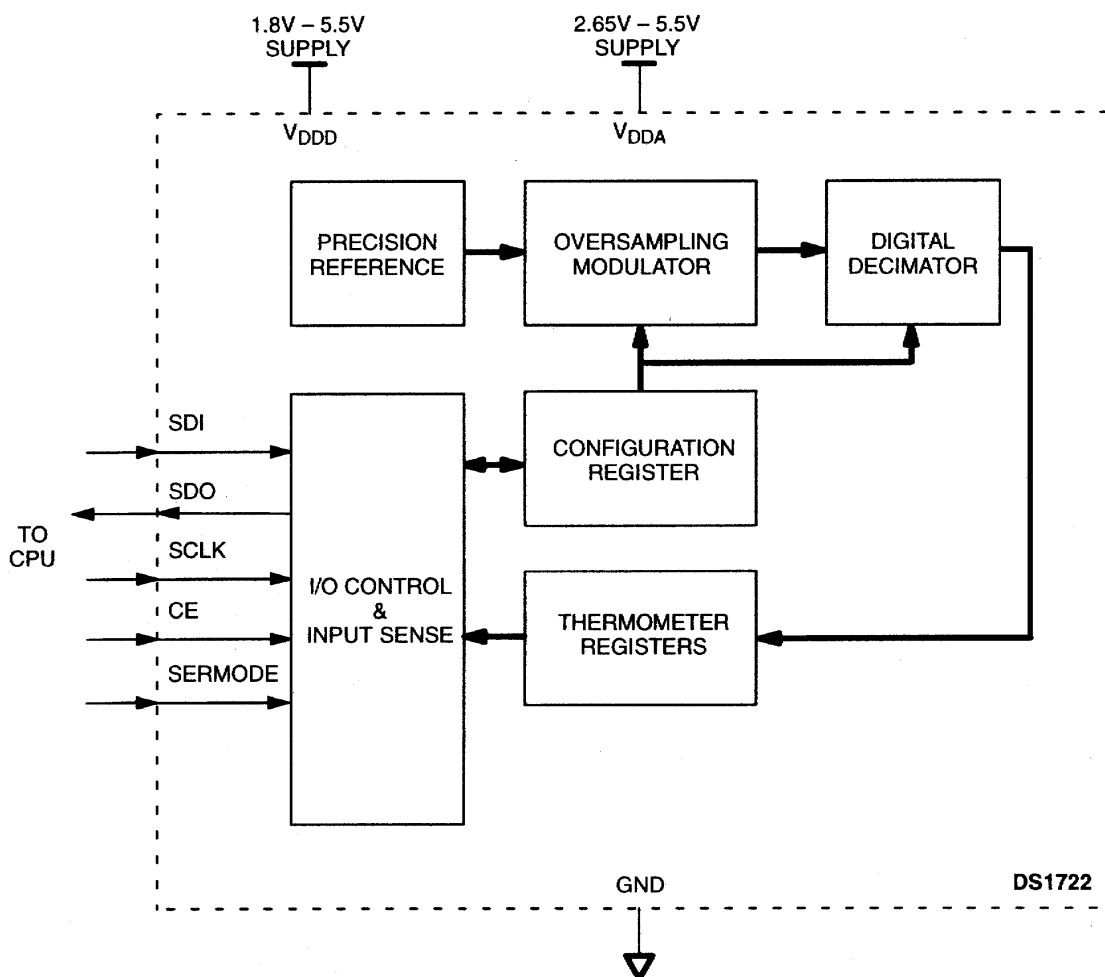

## OPERATION-Measuring Temperature

The core of DS1722 functionality is its direct-to-digital temperature sensor. The DS1722 measures temperature through the use of an on-chip temperature measurement technique with an operating range from  $-55^{\circ}$  to  $+120^{\circ}\text{C}$ . The device powers up in a power-conserving shutdown mode. After power-up, the DS1722 may be placed in a continuous conversion mode or in a one-shot conversion mode. In the continuous conversion mode, the device continuously computes the temperature and stores the most recent result in the temperature register at addresses 01h (LSB) and 02h (MSB). In the one-shot conversion mode, the DS1722 performs one temperature conversion and then returns to the shutdown mode, storing temperature in the temperature register. Details on how to change the setting after power-up are contained in the “OPERATION-Programming” section.

The resolution of the temperature conversion is configurable (8, 9, 10, 11, or 12 bits), with 9-bit readings the default state. This equates to a temperature resolution of  $1.0^{\circ}\text{C}$ ,  $0.5^{\circ}\text{C}$ ,  $0.25^{\circ}\text{C}$ ,  $0.125^{\circ}\text{C}$ , or  $0.0625^{\circ}\text{C}$ . Following each conversion, thermal data is stored in the thermometer register in two’s complement format; the information can be retrieved over the SPI or 3-wire interface with the address set to the temperature register, 01h (LSB) and then 02h (MSB). Table 3 describes the exact relationship of output data to measured temperature. The table assumes the DS1722 is configured for 12-bit resolution; if the device is configured in a lower resolution mode, those bits will contain 0s. The data is transmitted serially over the digital interface, MSb first for SPI communication and LSb first for 3-wire communication. The MSb of the temperature register contains the “sign” (S) bit, denoting whether the temperature is positive or negative. For Fahrenheit usage, a lookup table or conversion routine must be used.

### Temperature/Data Relationships Table 3

								Address Location
S	$2^6$	$2^5$	$2^4$	$2^3$	$2^2$	$2^1$	$2^0$	02h
MSb		(unit = $^{\circ}\text{C}$ )				LSb		
$2^{-1}$	$2^{-2}$	$2^{-3}$	$2^{-4}$	0	0	0	0	01h
TEMPERATURE	DIGITAL OUTPUT (BINARY)			DIGITAL OUTPUT (HEX)				
$+120^{\circ}\text{C}$	0111 1000 0000 0000			7800h				
$+25.0625^{\circ}\text{C}$	0001 1001 0001 0000			1910h				
$+10.125^{\circ}\text{C}$	0000 1010 0010 0000			0A20h				
$+0.5^{\circ}\text{C}$	0000 0000 1000 0000			0080h				
$0^{\circ}\text{C}$	0000 0000 0000 0000			0000h				
$-0.5^{\circ}\text{C}$	1111 1111 1000 0000			FF80h				
$-10.125^{\circ}\text{C}$	1111 0101 1110 0000			F5E0h				
$-25.0625^{\circ}\text{C}$	1110 0110 1111 0000			E6F0h				
$-55^{\circ}\text{C}$	1100 1001 0000 0000			C900h				

## OPERATION-Programming

The area of interest in programming the DS1722 is the Configuration register. All programming is done via the SPI or 3-wire communication interface by selecting the appropriate address of the desired register location. Table 4 illustrates the addresses for the two registers (configuration and temperature) of the DS1722.

**Register Address Structure Table 4**

Read Address	Write Address	Active Register
00h	80h	Configuration
01h	No access	Temperature LSB
02h	No access	Temperature MSB

## CONFIGURATION REGISTER PROGRAMMING

The configuration register is accessed in the DS1722 with the 00h address for reads and the 80h address for writes. Data is read from or written to the configuration register MSb first for SPI communication and LSb first for 3-wire communication. The format of the register is illustrated in Figure 2. The effect each bit has on DS1722 functionality is described below along with the power-up state of the bit. The entire register is volatile, and thus it will power-up in the default state.

**CONFIGURATION/STATUS REGISTER Figure 2**

1	1	1	1SHOT	R2	R1	R0	SD
MSb							LSb

**1SHOT** = One-shot temperature conversion bit. If the SD bit is "1", (continuous temperature conversions are not taking place), a "1" written to the 1SHOT bit will cause the DS1722 to perform one temperature conversion and store the results in the temperature register at addresses 01h (LSB) and 02h (MSB). The bit will clear itself to "0" upon completion of the temperature conversion. The user has read/write access to the 1SHOT bit, although writes to this bit will be ignored if the SD bit is a "0", (continuous conversion mode). The power-up default of the one-shot bit is "0".

**R0, R1, R2** = Thermometer resolution bits. Table 5 below defines the resolution of the digital thermometer, based on the settings of these 3 bits. There is a direct tradeoff between resolution and conversion time, as depicted in the AC Electrical Characteristics. The user has read/write access to the R2, R1 and R0 bits and the power-up default state is R2="0", R1="0", and R0="1" (9-bit conversions).

**THERMOMETER RESOLUTION CONFIGURATION Table 5**

R2	R1	R0	Thermometer Resolution	Max Conversion Time
0	0	0	8-bit	0.075s
0	0	1	9-bit	0.15s
0	1	0	10-bit	0.3s
0	1	1	11-bit	0.6s
1	x	x	12-bit	1.2s

**x=Don't care.**

**SD** = Shutdown bit. If SD is "0", the DS1722 will continuously perform temperature conversions and store the last completed result in the temperature register. If SD is changed to a "1", the conversion in progress will be completed and stored and then the device will revert to a low-power shutdown mode.

The communication port remains active. The user has read/write access to the SD bit and the power-up default is "1" (shutdown mode).

## SERIAL INTERFACE





The DS1722 offers the flexibility to choose between two serial interface modes. The DS1722 can communicate with the SPI interface or with a standard 3-wire interface. The interface method used is determined by the SERMODE pin. When this pin is connected to  $V_{DD}$  SPI communication is selected. When this pin is connected to ground, standard 3-wire communication is selected.

## SERIAL PERIPHERAL INTERFACE (SPI)

The serial peripheral interface (SPI) is a synchronous bus for address and data transfer. The SPI mode of serial communication is selected by tying the SERMODE pin to  $V_{DD}$ . Four pins are used for the SPI. The four pins are the SDO (Serial Data Out), SDI (Serial Data In), CE (Chip Enable), and SCLK (Serial Clock). The DS1722 is the slave device in an SPI application, with the microcontroller being the master. The SDI and SDO pins are the serial data input and output pins for the DS1722, respectively. The CE input is used to initiate and terminate a data transfer. The SCLK pin is used to synchronize data movement between the master (microcontroller) and the slave (DS1722) devices.

The shift clock (SCLK), which is generated by the microcontroller, is active only when CE is high and during address and data transfer to any device on the SPI bus. The inactive clock polarity is programmable in some microcontrollers. The DS1722 offers an important feature in that the level of the inactive clock is determined by sampling SCLK when CE becomes active. Therefore, either SCLK polarity can be accommodated. Input data (SDI) is latched on the internal strobe edge and output data (SDO) is shifted out on the shift edge (See Table 6 and Figure 3). There is one clock for each bit transferred. Address and data bits are transferred in groups of eight, MSB first.

**FUNCTION TABLE** Table 6

MODE	CE	SCLK	SDI	SDO
Disable Reset	L	Input Disabled	Input Disabled	High Z
Write	H	CPOL=1*  CPOL=0 	Data Bit Latch	High Z
Read	H	CPOL=1  CPOL=0 	X	Next data bit shift**

\*CPOL is the "Clock Polarity" bit that is set in the control register of the microcontroller.

\*\* SDO remains at High Z until eight bits of data are ready to be shifted out during a read.

### NOTE:

CPHA bit polarity must be set to "1".

## SERIAL CLOCK AS A FUNCTION OF MICROCONTROLLER CLOCK POLARITY (CPOL) Figure 3

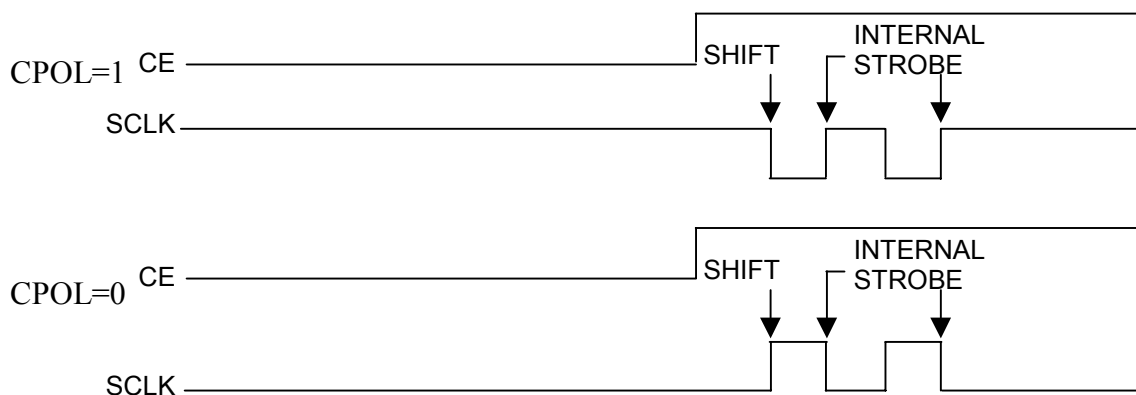

### NOTE:

CPOL is a bit that is set in the microcontroller's Control Register.

## ADDRESS AND DATA BYTES

Address and data bytes are shifted MSB first into the serial data input (SDI) and out of the serial data output (SDO). Any transfer requires the address of the byte to specify a write or a read, followed by one or more bytes of data. Data is transferred out of the SDO for a read operation and into the SDI for a write operation.

### SPI SINGLE BYTE WRITE Figure 4

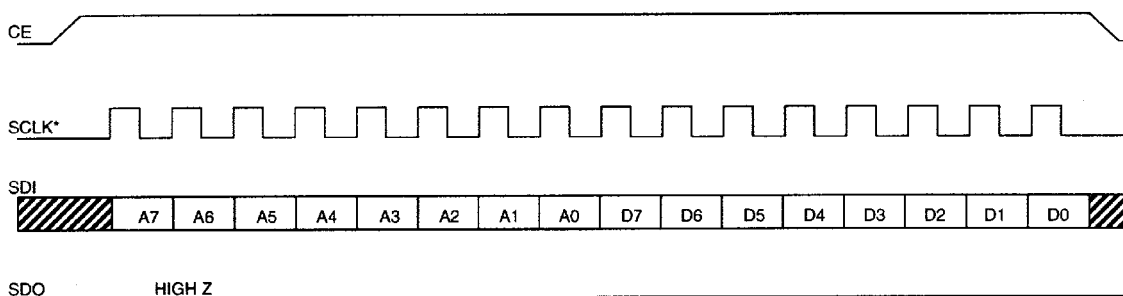

### SPI SINGLE-BYTE READ Figure 5

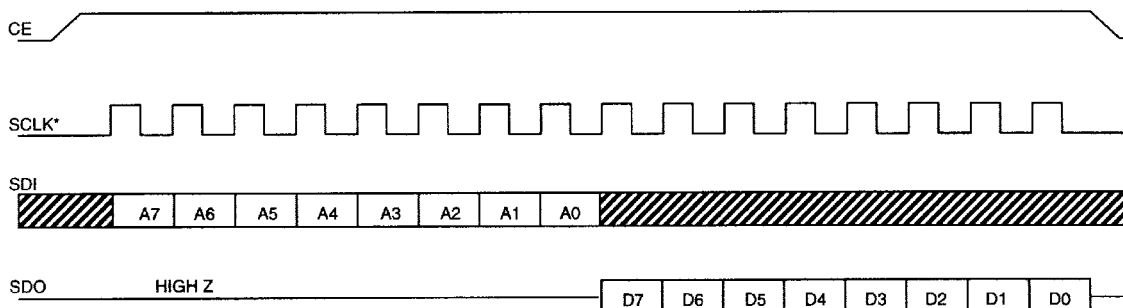

The address byte is always the first byte entered after CE is driven high. The most significant bit (A7) of this byte determines if a read or write will take place. If A7 is "0", one or more read cycles will occur. If A7 is "1", one or more write cycles will occur.

Data transfers can occur 1 byte at a time in multiple-byte burst mode. After CE is driven high an address is written to the DS1722. After the address, one or more data bytes can be written or read. For a single-byte transfer, 1 byte is read or written and then CE is driven low (see Figures 4 and 5). For a multiple-byte transfer, however, multiple bytes can be read or written to the DS1722 after the address has been written (see Figure 6). A single-byte burst read/write will sequentially point through the memory map and will loop from 02h/82h to 00h/80h.

## SPI MULTIPLE BYTE BURST TRANSFER Figure 6

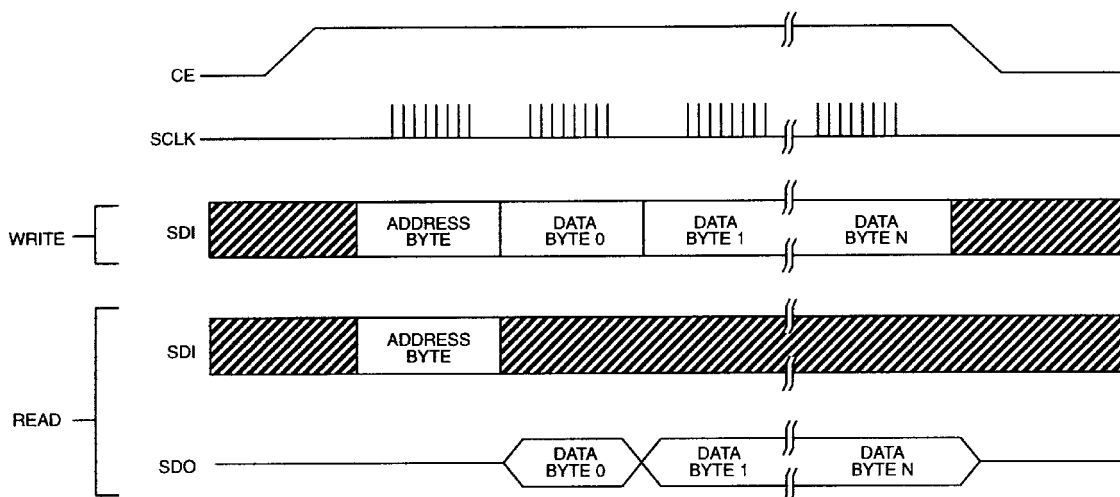

## 3-WIRE SERIAL DATA BUS

The 3-wire communication mode operates similar to the SPI mode. However, in 3-wire mode, there is one bi-directional I/O instead of separate data in and data out signals. The 3-wire consists of the I/O (SDI and SDO pins tied together), CE, and SCLK pins. In 3-wire mode, each byte is shifted in LSB first unlike SPI mode where each byte is shifted in MSB first. As is the case with the SPI mode, an address byte is written to the device followed by a single data byte or multiple data bytes. Figure 7 illustrates a read and write cycle. Figure 8 illustrates a multiple byte burst transfer. In 3-wire mode, data is input on the rising edge of SCLK and output on the falling edge of SCLK.

### 3-WIRE SINGLE BYTE TRANSFER Figure 7

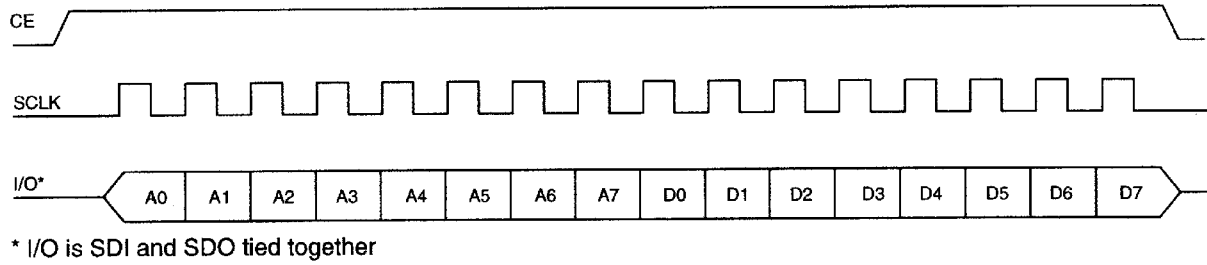

### 3-WIRE MULTIPLE BYTE BURST TRANSFER Figure 8

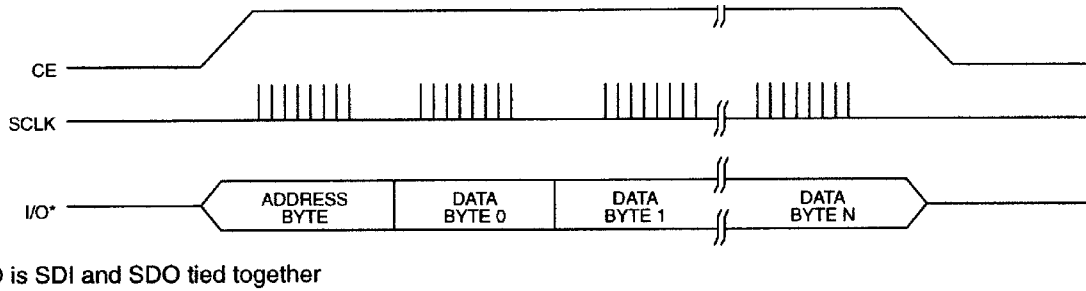

**ABSOLUTE MAXIMUM RATINGS\***

Voltage on $V_{DD}$ , Relative to Ground	-0.3V to +6.0V
Voltage on any other pin, Relative to Ground	-0.3V to +6.0V
Operating Temperature	-55°C to +125°C
Storage Temperature	-55°C to +125°C
Soldering Temperature	260°C for 10 seconds

\* This is a stress rating only and functional operation of the device at these or any other conditions above those indicated in the operation sections of this specification is not implied. Exposure to absolute maximum rating conditions for extended periods of time may affect reliability.

The Dallas Semiconductor DS1722 is built to the highest quality standards and manufactured for long term reliability. All Dallas Semiconductor devices are made using the same quality materials and manufacturing methods. However, the DS1722 is not exposed to environmental stresses, such as burn-in, that some industrial applications require. For specific reliability information on this product, please contact the factory in Dallas at (972) 371-4448.

**RECOMMENDED DC OPERATING CONDITIONS**

**(-55°C to +120°C, 2.65V ≤  $V_{DDA}$  ≤ 5.5V)**

PARAMETER	SYMBOL	CONDITION	MIN	TYP	MAX	UNITS	NOTES
Analog Supply Voltage	$V_{DDA}$		2.65		5.5	V	1
Digital Supply Voltage	$V_{DDD}$		1.8		5.5	V	1

**DC ELECTRICAL CHARACTERISTICS (-55°C to +120°C, 2.65V ≤  $V_{DDA}$  ≤ 5.5V)**

PARAMETER	SYMBOL	CONDITION	MIN	TYP	MAX	UNITS	NOTES
Input Logic High	$V_{IH}$		0.7 x $V_{DDD}$			V	1
Input Logic Low	$V_{IL}$				0.2 x $V_{DDD}$	V	1
Logic 0 Output	$V_{OL}$				0.2 x $V_{DDD}$	V	2
Logic 1 Output	$V_{OH}$		0.7 x $V_{DDD}$			V	3
Input Resistance	$R_I$	CE to GND SDI, SDO, SCLK to $V_{DDD}$	1 1			MΩ MΩ	
Active Current	$I_{CC}$				.5	mA	4
Shutdown Current	$I_{CC}$	2.65V ≤ $V_{DDA}$ ≤ 3.3V 3.3V ≤ $V_{DDA}$ ≤ 5.5V			0.5 1.0	μA μA	

**ELECTRICAL CHARACTERISTICS: DIGITAL THERMOMETER**(-55°C to +120°C, 2.65V ≤ V<sub>DDA</sub> ≤ 5.5V)

PARAMETER	SYMBOL	CONDITION	MIN	TYP	MAX	UNITS	NOTES
Thermometer Error	T <sub>ERR</sub>	-40°C to +85°C			±2.0	°C	8, 9
		-55°C to +120°C			±3.0		
Resolution			8		12	bits	
Conversion Time	t <sub>CONVT</sub>	8-bit conversions		67.5	75	ms	
		9-bit conversions		125	150		
		10-bit conversions		250	300		
		11-bit conversions		500	600		
		12-bit conversions		1000	1200		

**AC ELECTRICAL CHARACTERISTICS: 3-WIRE INTERFACE**(-55°C to +120°C, 2.65V ≤ V<sub>DD</sub> ≤ 5.5V)

PARAMETER	SYMBOL	CONDITION	MIN	TYP	MAX	UNITS	NOTES
Data to SCLK Setup	t <sub>DC</sub>		35			ns	5, 6
SCLK to Data Hold	t <sub>CDH</sub>		35			ns	5, 6
SCLK to Data Valid	t <sub>CDD</sub>				80	ns	5, 6, 7
SCLK Low Time	t <sub>CL</sub>		100			ns	6
SCLK High Time	t <sub>CH</sub>		100			ns	6
SCLK Frequency	t <sub>CLK</sub>		DC		5.0	MHz	6
SCLK Rise and Fall	t <sub>R</sub> , t <sub>F</sub>				200	ns	
CE to SCLK Setup	t <sub>CC</sub>		400			ns	6
SCLK to CE Hold	t <sub>CCH</sub>		100			ns	6
CE Inactive Time	t <sub>CWH</sub>		400			ns	6
CE to Output High Z	t <sub>CDZ</sub>				40	ns	5, 6
SCLK to Output High Z	t <sub>CCZ</sub>				40	ns	5, 6

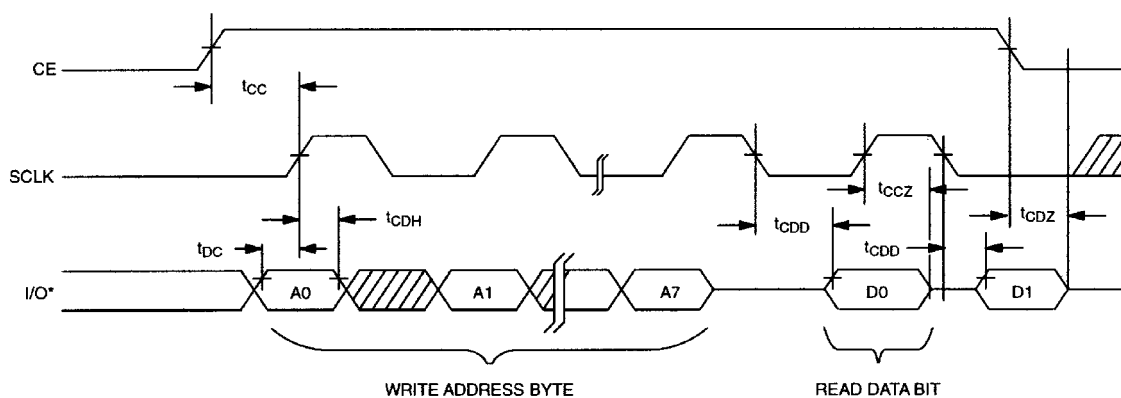
**TIMING DIAGRAM: 3-WIRE READ DATA TRANSFER** Figure 9

## TIMING DIAGRAM: 3-WIRE WRITE DATA TRANSFER Figure 10

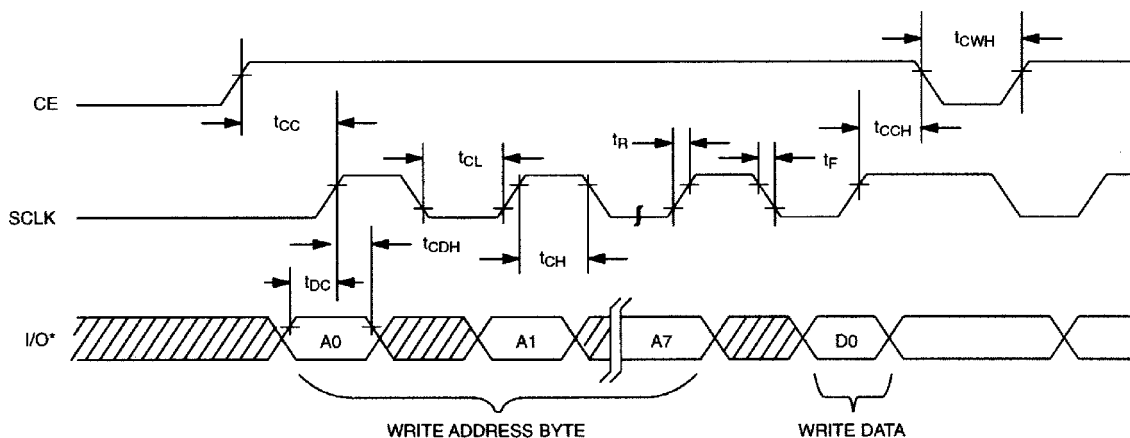

\*I/O is SDI and SDO tied together.

## AC ELECTRICAL CHARACTERISTICS: SPI Interface

(-55°C to +120°C, 2.65V ≤ V<sub>DD</sub> ≤ 5.5V)

PARAMETER	SYMBOL	CONDITION	MIN	TYP	MAX	UNITS	NOTES
Data to SCLK Setup	$t_{DC}$		35			ns	5, 6
SCLK to Data Hold	$t_{CDH}$		35			ns	5, 6
SCLK to Data Valid	$t_{CDD}$				80	ns	5, 6, 7
SCLK Low Time	$t_{CL}$		100			ns	6
SCLK High Time	$t_{CH}$		100			ns	6
SCLK Frequency	$t_{CLK}$		DC		5.0	MHz	6
SCLK Rise and Fall	$t_R, t_F$				200	ns	
CE to SCLK Setup	$t_{CC}$		400			ns	6
SCLK to CE Hold	$t_{CCH}$		100			ns	6
CE Inactive Time	$t_{CWH}$		400			ns	6
CE to Output High Z	$t_{CDZ}$				40	ns	5, 6

## TIMING DIAGRAM: SPI READ DATA TRANSFER Figure 11

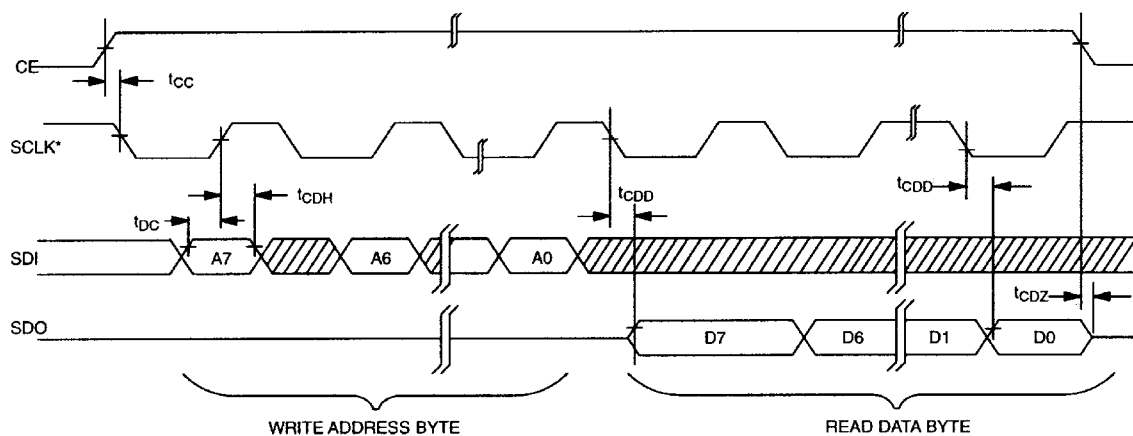

## TIMING DIAGRAM: SPI WRITE DATA TRANSFER Figure 12

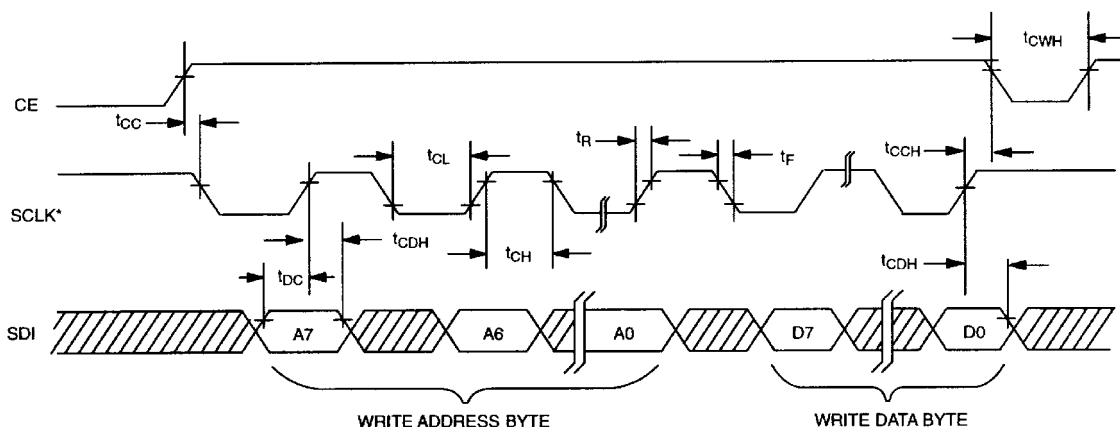

\*SCLK can be either polarity, timing shown for CPOL = 1.

### NOTES:

1. All voltages are referenced to ground.
2. Logic 0 voltages are specified at a sink current of 4 mA.
3. Logic 1 voltages are specified at a source current of 1 mA.
4.  $I_{CC}$  specified with  $SCLK=V_{DD}$  and  $CE=GND$ . Typical  $I_{CC1}$  is 0.25  $\mu A$  and  $I_{CC}$  is 0.3 mA at 25°C and  $V_{DD}=2.65V$ .
5. Measured at  $V_{IH}=0.7 V_{DD}$  or  $V_{IL}=0.2 V_{DD}$  and 10 ms maximum rise and fall time.
6. Measured with 50 pF load
7. Measured at  $V_{OH}=0.7 V_{DD}$  or  $V_{OL}=0.2 V_{DD}$ . Measured from the 50% point of SCLK to the  $V_{OH}$  minimum of SDO.
8. Figure 13 shows mean thermometer error for a pre-characterization sample. Data covering a larger sample over the full temperature range is pending.

# TYPICAL DS1722 THERMOMETER ERROR

