

# Application Circuit Examples

## ① Low Noise Light-sensitive Preamplifier

Used in receivers for spatial light transmission and optical remote control. A reverse bias is applied to the photodiode to improve frequency response. This circuit outputs an amplified signal from the FET drain, but signals can also be extracted from the source side for interface to the next stage circuit with small input resistance.

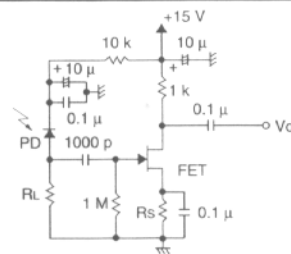

PD : High-speed PIN photodiodes (S2506, S5971, S5972, S5973, etc.)  
 RL : Determined by sensitivity and time constant of Ct of photodiode  
 Rs : Determined by operation point of FET  
 FET : 2SK152, 2SK192A, 2SK362, etc.

KPDC0014EB

## ② Low-level-light Sensor Head

The whole circuit is housed in a metallic box to eliminate external EMI (electromagnetic interference). The photodiode window size should be as small as possible. Use of an optical fiber to guide the signal light into the shield box is also effective in collecting light. If dry batteries are used and housed in the same shield box to supply power to the operational amplifier, noise originating from the AC source can be eliminated and the S/N ratio will be further improved.

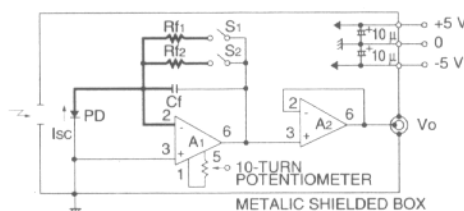

Bold lines should be within guarded layout or on teflon terminals.

A1 : AD549, OPA111, OPA128, etc. Rf : Up to 10 G Ω  
 A2 : OP07 S : Low-leakage reed relay  
 Cf : 10 to 100 pF, polystyrene capacitor PD : S1226/S1336/S2386 series, etc.

KPDC0016EA

## ③ Light Balance Detection Circuit

The output voltage  $V_o$  of this circuit is zero if the amount of light entering the two photodiodes PD<sub>1</sub> and PD<sub>2</sub> is equal. The photoelectric sensitivity is determined by the feedback resistance. By placing two diodes D in reverse parallel with each other,  $V_o$  will be limited to about  $\pm 0.5$  V (maximum) in an unbalanced state, so that the region around a balanced state can be detected with high sensitivity. Use of a quadrant photodiode allows two-dimensional optical axis alignment.

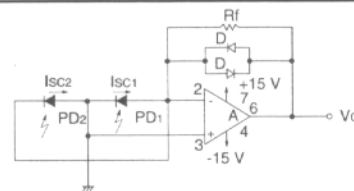

PD : S1226/S1336/S2386 series, etc.

A : LF356, etc.

D : IS1588, etc.

$V_o = R_f \times (I_{sc2} - I_{sc1})$  (V) ( $V_o < \pm 0.5$  V)

When the amount of light entering the two photodiodes is equal, the output voltage  $V_o$  will be zero. In unbalanced state,  $V_o$  will be  $\pm 0.3$  to 0.5 V. This circuit can be used for light balance detection between two specific wavelengths using optical filters.

KPDC0017EA

## ④ Luxmeter

This is an illuminometer using a visual-compensated photodiode S7160 and an operational amplifier. A maximum of 5000 lx can be measured with a voltmeter having a 5 V range. It is necessary to use an operational amplifier which can operate from a single voltage supply with a low bias current.

A standard lamp should be used to calibrate the illuminometer. If no standard lamp is available, an incandescent lamp of 100 W can be used for approximate calibrations. To make calibrations, first select the 10 mV/lx range in the figure at the right and short the wiper terminal of the 500 Ω variable resistor VR and the output terminal of the operational amplifier. Adjust the distance between the photodiode and the incandescent lamp so that the voltmeter reads 3.8 V. At this point, illuminance on the S7160 photodiode surface is about 100 lx. Then open the shorted terminals and adjust VR so that the voltmeter reads 1.0 V. Calibration has now been completed.

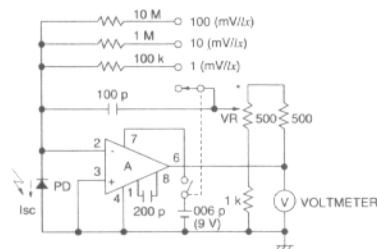

A : CA3130 (ICL7611 or equivalent devices can also be used.)

PD : S7160 (3.8 µA/100 lx)

\* : Meter calibration potentiometer

KPDC0018EA

## ⑤ Light Sensor Using High-speed Operational Amplifier (1)

This circuit uses a high-speed photodiode applied at a reverse voltage and a current-to-voltage conversion operational amplifier. The time response of the circuit greatly depends on the time constant of the feedback resistance  $R_f$  and its parallel stray capacitance. To minimize the effect of this time constant, two or more resistors are connected in series as the feedback resistance to disperse the parallel stray capacitance. Use of chip resistors as the feedback resistance will be effective in reducing the stray capacitance.

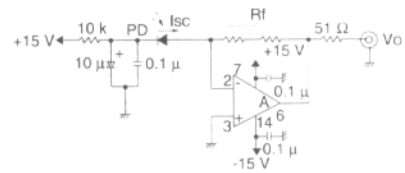

PD: High-speed PIN photodiodes (S2506, S5971, S5972, S5973, etc.)  
 $R_f$ : Two or more resistors are connected in series to eliminate parallel capacitance.  
 A: OPA620, AD743, AD849, HA5160, etc.

KPOC0020EB

## ⑥ Light Sensor Using High-speed Operational Amplifier (2)

This light detection circuit uses a high-speed, current-feedback operational amplifier, and allows direct connection to a coaxial cable. Because this circuit performs signal amplification after current-to-voltage conversion by load resistance  $R_L$ , there will be no detrimental effects which result from a phase shift in the amplifier. As with the circuit ⑤, two or more resistors are used as the feedback resistance to disperse parallel stray capacitance in the resistors. A ceramic capacitor of 0.1 μF is connected to the power supply pin of the IC, and should be grounded at a minimum distance. For bandwidths over 100 MHz, use of chip resistors and capacitors is recommended to reduce the entire circuit size and suppress the undesired effects of lead inductance of each component. Performance can also be improved by using a ground plane structure in which the entire copper foil surface on the PCB is used at the ground potential.

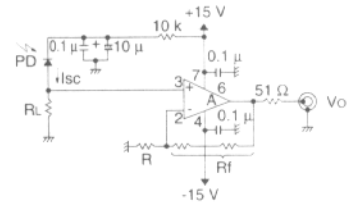

PD: High-speed PIN photodiodes (S2506, S5971, S5972, S5973, etc.)  
 $R_L$ ,  $R_f$ : Determined by recommended conditions of the Op-amp  
 A: OPA648, OPA658, AD8001, etc.  
 $V_o = I_{sc} \times R_L \times (1 + \frac{R_f}{R})$  [V]

KPOC0015EA

## ⑦ Light-to-logarithmic-voltage Conversion Circuit

The output voltage of this circuit is proportional to the logarithmic change in the detected light level. A base-emitter junction of small signal transistors or a diode between the gate-source of junction FETs can be used as the log diode  $D_1$ .  $I_b$  is the current source that supplies the log diode with a bias current. If  $I_b$  is not present, the circuit will be unstable or latched up when  $I_{sc}$  by the incident light decreases to zero.

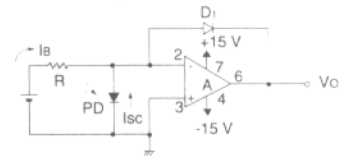

$D_1$ : Diode of low dark current and low series resistance  
 $I_b$ : Current source for setting circuit operation point,  $I_b \ll I_{sc}$   
 $R$ : 1 G to 10 GΩ  
 $I_o$ :  $D_1$  saturation current,  $10^{-15}$  to  $10^{-12}$  A  
 A: FET input Op-amp  
 $V_o \approx -0.06 \log(\frac{I_{sc} + I_b}{I_o} + 1)$  [V]

KPOC0021EA

## ⑧ High-speed Light Detector Using PIN Photodiode

Unlike the above circuits ②, ⑥ and ⑦, this circuit uses no active components. Since no signal amplification is performed, this circuit is mainly used for detection at relatively high light levels. The impedance matching load resistance of 50 Ω can be directly connected to the 50 Ω input terminal of an oscilloscope or other measurement equipment.

High-speed photodiodes designed for the GHz range can be used with this circuit. A chip capacitor should be used as the bypass capacitor C. The photodiode leads and the conductors of the coaxial cable where high-frequency current flows should be made as short as possible. Since the signal current flows instantaneously to the load from the capacitor C in the figure, it is necessary to select the capacitance that supplies the corresponding electric charge.

In the figure at the right, if the cable is not terminated, the center conductor is charged up at the power supply potential. If a high reverse bias is used, sufficient caution must be taken not to exceed the maximum rating of the input circuit of the measurement equipment, otherwise the equipment may be damaged.

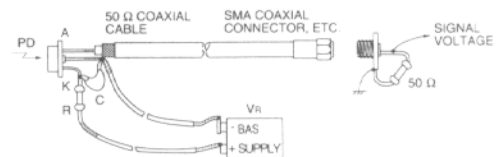

PD: High-speed PIN photodiodes (S2506, S5971, S5972, S5973, etc.)  
 $R$ : 10 kΩ, Voltage drop by photocurrent should be sufficiently smaller than  $V_b$ .  
 $C$ : 0.1 μF ceramic capacitor

The leads of PD and C from coaxial cable should be as short as possible.  
 (Chip components are recommended.)

KPOC0022EB

## 9 CT Scanner, X-ray Monitor

In this application, scintillators are used to convert gamma-ray or X-ray into UV or visible light which is detected by the photodiode coupled to the scintillator. Aluminum foil is used to wrap the scintillator to prevent background light from entering the photodiode through the scintillator. At the same time, the aluminum foil collects the generated light effectively onto the photodiode.

Beta-ray can also be detected with the same circuit configuration. However, it is necessary to use a light-shielding material which permits efficient transmission of beta-ray.

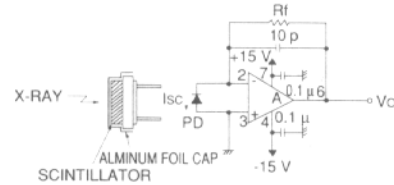

PD : S3590 series, etc.  
 Rf : 10 M to 100 M Ω  
 A : FET Op-amp (OPA111, etc.)  
 Scintillator: CdWO<sub>4</sub>, BGO, etc. adhered to photodiode

KPDC0023EA

## 10 Gamma-ray, X-ray Detector

When radiation is absorbed or scattered in a photodiode, a charge is generated at that portion. This charge can be output to an external circuit just as with detection of light. A<sub>1</sub> used in this circuit is a charge amplifier which converts a charge generated through the above process into a voltage pulse. An operational amplifier with a large slew rate but small bias current should be selected for A<sub>1</sub>. Use of a photodiode with smaller active area offers a small junction capacitance and thus provides a large output pulse, although at the expense of detection efficiency. As in the case of 9, aluminum foil or similar material should be used to shield background light.

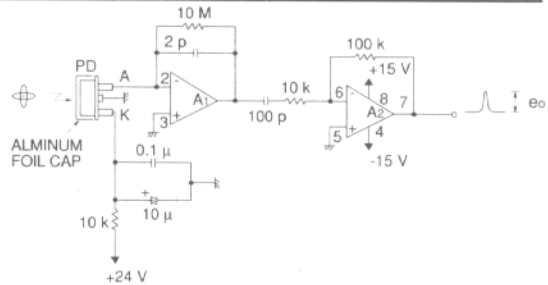

PD : S3071  
 A<sub>1</sub>, A<sub>2</sub>: LF442  
 eo : Several mV to tens of mV for cobalt 60

KPDC0024EA

## 11 Light Absorption Meter

This is a light absorption meter using a processor module (A in the figure) which provides a logarithmic ratio of two current inputs. By measuring and comparing the light intensity transmitting through a sample with two photodiodes, a voltage output corresponding to light absorbance by the sample can be obtained. To make measurements, the incident aperture should first be adjusted so that the amount of light entering the two photodiodes or photocurrent is equal. Next, the sample is placed on the light path of one photodiode as shown in the figure. At this point, the absorbance A by the sample can be directly read as  $A = -V_o$  (V) on the voltmeter. For example, when a sample with an absorbance of 1 (transmittance 10%) is detected, the output voltage will be -1 V. If a filter is interposed as shown in the figure, the absorbance of specific light spectrum or monochromatic light can be measured.

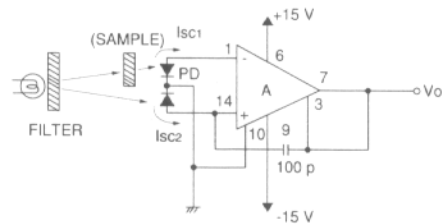

A : The above figure uses LOG100 (Burr Brown). Analog Devices 755N/P can be also used.  
 PD: S2841, S1446, G1964, etc.  
 Vo:  $V_o = \log(I_{sc1}/I_{sc2})$  [V]  
 Absorbance A by the sample can be read as  $A = -V_o$  (V) when  $I_{sc1}$  is equal to  $I_{sc2}$  without the sample.

KPDC0025EA

## 12 Total Emission Measurement of LED

This circuit is used to measure the amount of light emitted from an LED. Since the emitting spectral width of LEDs is usually as narrow as about 50 nm, the amount of the LED emission can be calculated from the photodiode radiant sensitivity at a peak emission wavelength of the LED. In the figure at the right, the inner surface of the reflector block B is mirror-processed so that it reflects the light emitted from the side of the LED towards the photodiode. Therefore, the total amount of the LED emission can be detected by the photodiode.

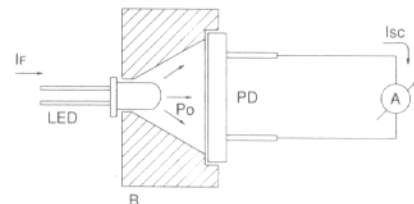

A : Ammeter, 1 to 10 mA  
 PD: S2387-1010R  
 B : Aluminum block, inner metal plating  
 Po : Total emission  $P_o = I_{sc}/S$  [W]  
 Refer to the spectral response chart for the photo sensitivity S of the photodiode.  
 Example:  $S = 0.58$  A/W ( $\lambda = 930$  nm)

KPDC0026EA

## 13 Light Integration Circuit

This circuit is used to measure the integrated power or average power of a light pulse train with an erratic pulse height, cycle and width. The integrator A in the figure accumulates photocurrent generated by each light pulse in the integration capacitance C. By measuring the output voltage  $V_o$  immediately before reset, the average output current  $I_{sc}$  can be obtained from the integration time  $t$  and the capacitance C. A low dielectric absorption type capacitor should be used as the capacitance C to eliminate reset errors. The switch S is a C-MOS analog switch.

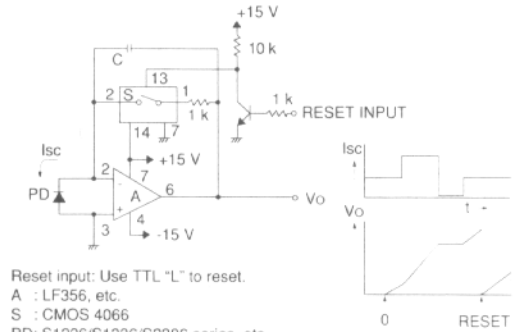

Reset input: Use TTL "L" to reset.  
 A : LF356, etc.  
 S : CMOS 4066  
 PD: S1226/S1336/S2386 series, etc.  
 C : Polycarbonate capacitor  
 $V_o = I_{sc} \times t \times \frac{1}{C}$  [V]

KPDC0027EA

## 14 Light-to-frequency Conversion Circuit

Making use of a C-MOS timer IC, this circuit generates pulses at a frequency proportional to the amount of light. The capacitance C is charged with a constant current  $I_{sc}$  generated from the photodiode. When the potential of C increases and reaches 2/3 of the supply voltage, the timer IC allows C to begin discharging and its potential lowers. This discharge will stop when the potential of C lowers to 1/3 of the supply voltage. For the calculation in the figure, the output pulse low duration is ignored as it is very short. The duration is  $C \times 100 \text{ k}\Omega$ .

While repeating the above process, the timer IC generates square wave pulses whose frequency is proportional to the amount of detected light. Since the reference voltage is created by dividing the supply voltage in the IC, the output frequency varies with the supply voltage.

A bipolar timer IC (type 555) cannot be used because its terminal current is usually larger than  $I_{sc}$ .

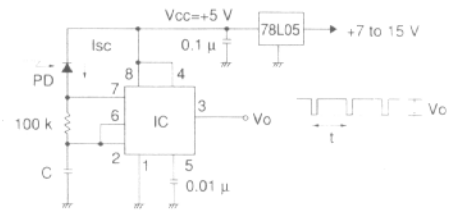

PD: S1087  
 IC : MPD5555 (C-MOS timer IC)  
 $f = \frac{1}{t} = \frac{3}{V_{cc}} \times \frac{I_{sc}}{C}$  [Hz]  
 e.g.  $f = 80 \text{ Hz}$  at  $100 \text{ lx}$  when  $C = 0.001 \text{ }\mu\text{F}$

KPDC0028EA

## 15 Light-to-frequency Conversion Circuit Using PUT (Refer to PAT. No. 1975639)

This circuit converts light into a pulse train at a frequency proportional to the amount of light. A major difference from the circuit 14 is that the pulse oscillation stops if the amount of light exceeds a certain threshold level. Light-to-frequency conversion is nearly proportional in the specified range and the current consumption is small.

An approximate oscillation frequency obtained with this circuit can be calculated by the equation shown in the figure. When using constants shown in the figure, this circuit operates in the range from about  $1 \text{ lx}$  to  $200 \text{ lx}$ , with a light-to-frequency conversion ratio of  $1.4 \text{ Hz/lx}$ . The current consumption is approximately  $10 \text{ }\mu\text{A}$ .

The upper and lower limits of light level are determined by the valley and peak currents of the PUT with respect to the combined gate resistance. The gate resistance should be selected so that the photodiode current is in this range.

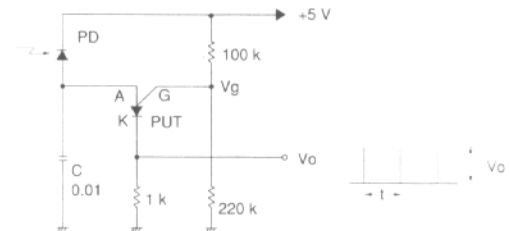

PD : S2386-5K  
 PUT : N13T2 (NEC), TN41B (TOSHIBA), etc.  
 $t = V_g \times \frac{C}{I_{sc}}$  [s]

KPDC0029EA

Operational amplifiers used in these circuit examples will differ in such factors as operating ambient temperature range, bias current, phase compensation and offset adjustment method depending on the type used. Refer to the manufacturer's data sheet or instruction manual.

Typical operational amplifiers, and buffer amplifiers:

Analog Devices: AD549, 755N/P, OP07, AD743, AD849, AD8001  
 Burr Brown: OPA111, OPA128, OPA620, LOG100, OPA648, OPA658  
 National Semiconductor: LF357, LF356, LF442  
 Harris: HA2625, HA5160, CA3130, ICL7611

Sample circuits listed in this catalog introduce typical applications of Hamamatsu photodiodes and do not cover any guarantee of the circuit design. No patent rights are granted to any of the circuits described herein.