

- **Very Low Power Consumption**
  - 1 mW Typ at  $V_{DD} = 5\text{ V}$
- **Capable of Operation in Astable Mode**
- **CMOS Output Capable of Swinging Rail to Rail**
- **High Output-Current Capability**
  - Sink 100 mA Typ
  - Source 10 mA Typ
- **Output Fully Compatible With CMOS, TTL, and MOS**
- **Low Supply Current Reduces Spikes During Output Transitions**
- **Single-Supply Operation From 2 V to 15 V**
- **Functionally Interchangeable With the NE555; Has Same Pinout**
- **ESD Protection Exceeds 2000 V Per MIL-STD-883C, Method 3015.2**

**D, DB, JG, P, OR PW PACKAGE  
(TOP VIEW)**

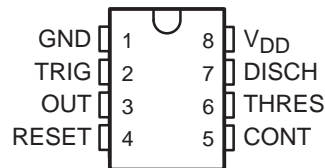

**FK PACKAGE  
(TOP VIEW)**

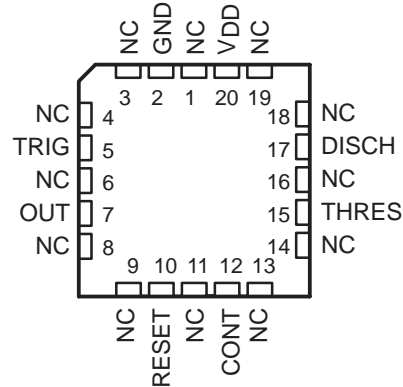

NC – No internal connection

**description**

The TLC555 is a monolithic timing circuit fabricated using the TI LinCMOS™ process. The timer is fully compatible with CMOS, TTL, and MOS logic and operates at frequencies up to 2 MHz. Because of its high input impedance, this device uses smaller timing capacitors than those used by the NE555. As a result, more accurate time delays and oscillations are possible. Power consumption is low across the full range of power supply voltage.

Like the NE555, the TLC555 has a trigger level equal to approximately one-third of the supply voltage and a threshold level equal to approximately two-thirds of the supply voltage. These levels can be altered by use of the control voltage terminal (CONT). When the trigger input (TRIG) falls below the trigger level, the flip-flop is set and the output goes high. If TRIG is above the trigger level and the threshold input (THRES) is above the threshold level, the flip-flop is reset and the output is low. The reset input (RESET) can override all other inputs and can be used to initiate a new timing cycle. If RESET is low, the flip-flop is reset and the output is low. Whenever the output is low, a low-impedance path is provided between the discharge terminal (DISCH) and GND. All unused inputs should be tied to an appropriate logic level to prevent false triggering.

While the CMOS output is capable of sinking over 100 mA and sourcing over 10 mA, the TLC555 exhibits greatly reduced supply-current spikes during output transitions. This minimizes the need for the large decoupling capacitors required by the NE555.

The TLC555C is characterized for operation from 0°C to 70°C. The TLC555I is characterized for operation from – 40°C to 85°C. The TLC555M is characterized for operation over the full military temperature range of – 55°C to 125°C.



Please be aware that an important notice concerning availability, standard warranty, and use in critical applications of Texas Instruments semiconductor products and disclaimers thereto appears at the end of this data sheet.

LinCMOS is a trademark of Texas Instruments.

PRODUCTION DATA information is current as of publication date. Products conform to specifications per the terms of Texas Instruments standard warranty. Production processing does not necessarily include testing of all parameters.



# TLC555 LinCMOS™ TIMER

SLFS043D – SEPTEMBER 1983 – REVISED SEPTEMBER 2000

## AVAILABLE OPTIONS

PACKAGED DEVICES							
T <sub>A</sub>	V <sub>DD</sub> RANGE	SMALL OUTLINE (D)†	SSOP (DB)†	CHIP CARRIER (FK)	CERAMIC DIP (JG)	PLASTIC DIP (P)	TSSOP (PW)†
0°C to 70°C	2 V to 15 V	TLC555CD	TLC555CDB	—	—	TLC555CP	TLC555CPW
– 40°C to 85°C	3 V to 15 V	TLC555ID	—	—	—	TLC555IP	—
–55°C to 125°C	5 V to 15 V	TLC555MD	—	TLC555MFK	TLC555MJG	TLC555MP	—

† This package is available taped and reeled. Add the R suffix to device type (e.g., TLC555CDR).

## FUNCTION TABLE

RESET VOLTAGE‡	TRIGGER VOLTAGE‡	THRESHOLD VOLTAGE‡	OUTPUT	DISCHARGE SWITCH
<MIN	Irrelevant	Irrelevant	L	On
>MAX	<MIN	Irrelevant	H	Off
>MAX	>MAX	>MAX	L	On
>MAX	>MAX	<MIN	As previously established	

‡ For conditions shown as MIN or MAX, use the appropriate value specified under electrical characteristics.

## functional block diagram

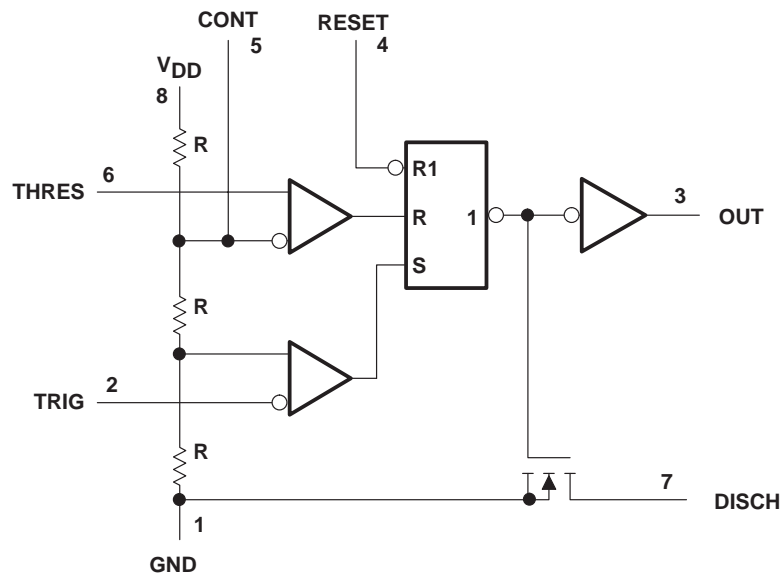

Pin numbers are for all packages except the FK package.  
RESET can override TRIG, which can override THRES.

equivalent schematic (each channel)

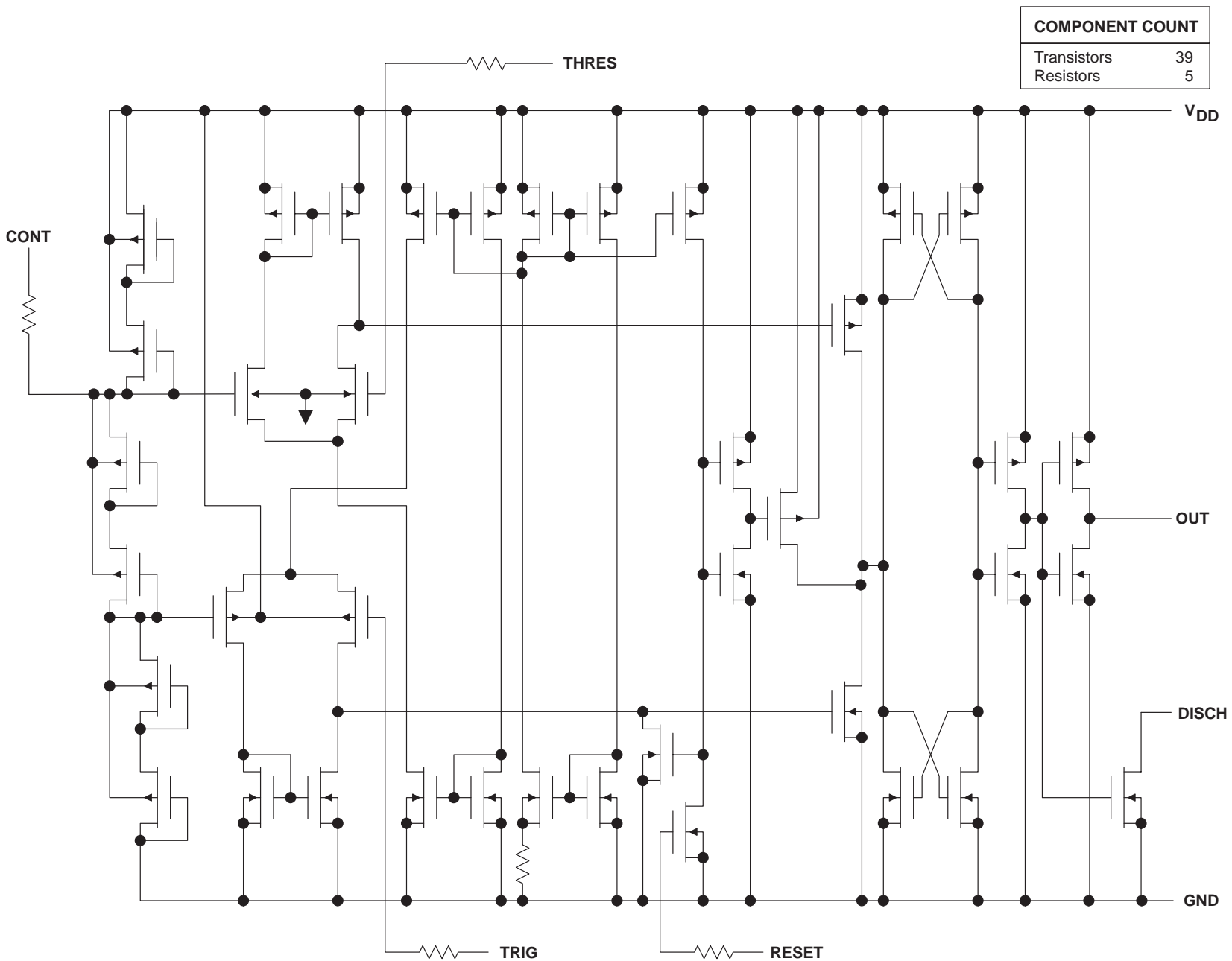



**electrical characteristics at specified free-air temperature,  $V_{DD} = 2\text{ V}$  for TLC555C,  $V_{DD} = 3\text{ V}$  for TLC555I**

PARAMETER	TEST CONDITIONS	$T_A$ †	TLC555C			TLC555I			UNIT
			MIN	TYP	MAX	MIN	TYP	MAX	
$V_{IT}$ Threshold voltage		25°C	0.95	1.33	1.65	1.6		2.4	V
		Full range	0.85		1.75	1.5		2.5	
$I_{IT}$ Threshold current		25°C	10			10			pA
		MAX	75			150			
$V_{I(TRIG)}$ Trigger voltage		25°C	0.4	0.67	0.95	0.71	1	1.29	V
		Full range	0.3		1.05	0.61		1.39	
$I_{I(TRIG)}$ Trigger current		25°C	10			10			pA
		MAX	75			150			
$V_{I(RESET)}$ Reset voltage		25°C	0.4	1.1	1.5	0.4	1.1	1.5	V
		Full range	0.3		2	0.3		1.8	
$I_{I(RESET)}$ Reset current		25°C	10			10			pA
		MAX	75			150			
Control voltage (open circuit) as a percentage of supply voltage		MAX	66.7%			66.7%			
Discharge switch on-stage voltage	$I_{OL} = 1\text{ mA}$	25°C	0.03			0.03			V
		Full range	0.2			0.25			
Discharge switch off-stage current		25°C	0.1			0.1			nA
		MAX	0.5			120			
$V_{OH}$ High-level output voltage	$I_{OH} = -300\text{ }\mu\text{A}$	25°C	1.5	1.9		1.5	1.9		V
		Full range	1.5			2.5			
$V_{OL}$ Low-level output voltage	$I_{OL} = 1\text{ mA}$	25°C	0.07			0.07			V
		Full range	0.3			0.35			
$I_{DD}$ Supply current	See Note 2	25°C	250			250			$\mu\text{A}$
		Full range	400			500			

† Full range is 0°C to 70°C for the TLC555C and –40°C to 85°C for the TLC555I. For conditions shown as MAX, use the appropriate value specified in the recommended operating conditions table.

NOTE 2: These values apply for the expected operating configurations in which THRES is connected directly to DISCH or to TRIG.

# TLC555 LinCMOS™ TIMER

SLFS043D – SEPTEMBER 1983 – REVISED SEPTEMBER 2000

## electrical characteristics at specified free-air temperature, $V_{DD} = 5\text{ V}$

PARAMETER	TEST CONDITIONS	$T_A$ †	TLC555C			TLC555I			TLC555M			UNIT
			MIN	TYP	MAX	MIN	TYP	MAX	MIN	TYP	MAX	
$V_{IT}$ Threshold voltage		25°C	2.8	3.3	3.8	2.8	3.3	3.8	2.8	3.3	3.8	V
		Full range	2.7		3.9	2.7		3.9	2.7		3.9	
$I_{IT}$ Threshold current		25°C	10			10			10			pA
		MAX	75			150			5000			
$V_{I(TRIG)}$ Trigger voltage		25°C	1.36	1.66	1.96	1.36	1.66	1.96	1.36	1.66	1.96	V
		Full range	1.26		2.06	1.26		2.06	1.26		2.06	
$I_{I(TRIG)}$ Trigger current		25°C	10			10			10			pA
		MAX	75			150			5000			
$V_{I(RESET)}$ Reset voltage		25°C	0.4	1.1	1.5	0.4	1.1	1.5	0.4	1.1	1.5	V
		Full range	0.3		1.8	0.3		1.8	0.3		1.8	
$I_{I(RESET)}$ Reset current		25°C	10			10			10			pA
		MAX	75			150			5000			
Control voltage (open circuit) as a percentage of supply voltage		MAX	66.7%			66.7%			66.7%			
Discharge switch on-state voltage	$I_{OL} = 10\text{ mA}$	25°C	0.14		0.5	0.14		0.5	0.14		0.5	V
		Full range			0.6			0.6			0.6	
Discharge switch off-state current		25°C	0.1			0.1			0.1			nA
		MAX	0.5			120			120			
$V_{OH}$ High-level output voltage	$I_{OH} = -1\text{ mA}$	25°C	4.1	4.8		4.1	4.8		4.1	4.8		V
		Full range	4.1			4.1			4.1			
$V_{OL}$ Low-level output voltage	$I_{OL} = 8\text{ mA}$	25°C	0.21		0.4	0.21		0.4	0.21		0.4	V
		Full range			0.5			0.5			0.6	
	$I_{OL} = 5\text{ mA}$	25°C	0.13		0.3	0.13		0.3	0.13		0.3	
		Full range			0.4			0.4			0.45	
	$I_{OL} = 3.2\text{ mA}$	25°C	0.08		0.3	0.08		0.3	0.08		0.3	
		Full range			0.35			0.35			0.4	
$I_{DD}$ Supply current	See Note 2	25°C	170		350	170		350	170		350	$\mu\text{A}$
		Full range			500			600			700	

† Full range is 0°C to 70°C the for TLC555C, – 40°C to 85°C for the TLC555I, and – 55°C to 125°C for the TLC555M. For conditions shown as MAX, use the appropriate value specified in the recommended operating conditions table.

NOTE 2: These values apply for the expected operating configurations in which THRES is connected directly to DISCH or TRIG.

**electrical characteristics at specified free-air temperature,  $V_{DD} = 15\text{ V}$**

PARAMETER	TEST CONDITIONS	$T_A$ †	TLC555C			TLC555I			TLC555M			UNIT
			MIN	TYP	MAX	MIN	TYP	MAX	MIN	TYP	MAX	
$V_{IT}$ Threshold voltage		25°C	9.45	10	10.55	9.45	10	10.55	9.45	10	10.55	V
		Full range	9.35		10.65	9.35		10.65	9.35		10.65	
$I_{IT}$ Threshold current		25°C		10			10			10		pA
		MAX		75			150			5000		
$V_{I(TRIG)}$ Trigger voltage		25°C	4.65	5	5.35	4.65	5	5.35	4.65	5	5.35	V
		Full range	4.55		5.45	4.55		5.45	4.55		5.45	
$I_{I(TRIG)}$ Trigger current		25°C		10			10			10		pA
		MAX		75			150			5000		
$V_{I(RESET)}$ Reset voltage		25°C	0.4	1.1	1.5	0.4	1.1	1.5	0.4	1.1	1.5	V
		Full range	0.3		1.8	0.3		1.8	0.3		1.8	
$I_{I(RESET)}$ Reset current		25°C		10			10			10		pA
		MAX		75			150			5000		
Control voltage (open circuit) as a percentage of supply voltage		MAX	66.7%			66.7%			66.7%			
Discharge switch on-state voltage	$I_{OL} = 100\text{ mA}$	25°C		0.77	1.7		0.77	1.7		0.77	1.7	V
		Full range			1.8			1.8			1.8	
Discharge switch off-state current		25°C		0.1			0.1			0.1		nA
		MAX		0.5			120			120		
$V_{OH}$ High-level output voltage	$I_{OH} = -10\text{ mA}$	25°C	12.5	14.2		12.5	14.2		12.5	14.2		V
		Full range	12.5			12.5			12.5			
	$I_{OH} = -5\text{ mA}$	25°C	13.5	14.6		13.5	14.6		13.5	14.6		
		Full range	13.5			13.5			13.5			
	$I_{OH} = -1\text{ mA}$	25°C	14.2	14.9		14.2	14.9		14.2	14.9		
		Full range	14.2			14.2			14.2			
$V_{OL}$ Low-level output voltage	$I_{OL} = 100\text{ mA}$	25°C		1.28	3.2		1.28	3.2		1.28	3.2	V
		Full range			3.6			3.7			3.8	
	$I_{OL} = 50\text{ mA}$	25°C		0.63	1		0.63	1		0.63	1	
		Full range			1.3			1.4			1.5	
	$I_{OL} = 10\text{ mA}$	25°C		0.12	0.3		0.12	0.3		0.12	0.3	
		Full range			0.4			0.4			0.45	
$I_{DD}$ Supply current	See Note 2	25°C		360	600		360	600		360	600	μA
		Full range			800			900			1000	

† Full range is 0°C to 70°C for TLC555C, – 40°C to 85°C for TLC555I, and – 55°C to 125°C for TLC555M. For conditions shown as MAX, use the appropriate value specified in the recommended operating conditions table.

NOTE 2: These values apply for the expected operating configurations in which THRES is connected directly to DISCH or TRIG.

# TLC555 LinCMOS™ TIMER

SLFS043D – SEPTEMBER 1983 – REVISED SEPTEMBER 2000

## operating characteristics, $V_{DD} = 5\text{ V}$ , $T_A = 25^\circ\text{C}$ (unless otherwise noted)

PARAMETER	TEST CONDITIONS	MIN	TYP	MAX	UNIT
Initial error of timing interval‡	$V_{DD} = 5\text{ V to }15\text{ V}$ , $R_A = R_B = 1\text{ k}\Omega\text{ to }100\text{ k}\Omega$ , $C_T = 0.1\text{ }\mu\text{F}$ , See Note 3		1%	3%	
Supply voltage sensitivity of timing interval			0.1	0.5	%/V
$t_r$ Output pulse rise time	$R_L = 10\text{ M}\Omega$ , $C_L = 10\text{ pF}$		20	75	ns
$t_f$ Output pulse fall time			15	60	
$f_{max}$ Maximum frequency in astable mode	$R_A = 470\text{ }\Omega$ , $R_B = 200\text{ }\Omega$ , $C_T = 200\text{ pF}$ , See Note 3	1.2	2.1		MHz

‡ Timing interval error is defined as the difference between the measured value and the average value of a random sample from each process run.

NOTE 3:  $R_A$ ,  $R_B$ , and  $C_T$  are as defined in Figure 1.

## electrical characteristics at $V_{DD} = 5\text{ V}$ , $T_A = 25^\circ\text{C}$

PARAMETER	TEST CONDITIONS	MIN	TYP	MAX	UNIT
$V_{IT}$ Threshold voltage		2.8	3.3	3.8	V
$I_{IT}$ Threshold current			10		pA
$V_{I(TRIG)}$ Trigger voltage		1.36	1.66	1.96	V
$I_{I(TRIG)}$ Trigger current			10		pA
$V_{I(RESET)}$ Reset voltage		0.4	1.1	1.5	V
$I_{I(RESET)}$ Reset current			10		pA
Control voltage (open circuit) as a percentage of supply voltage			66.7%		
Discharge switch on-state voltage	$I_{OL} = 10\text{ mA}$		0.14	0.5	V
Discharge switch off-state current			0.1		nA
$V_{OH}$ High-level output voltage	$I_{OH} = -1\text{ mA}$	4.1	4.8		V
$V_{OL}$ Low-level output voltage	$I_{OL} = 8\text{ mA}$		0.21	0.4	V
	$I_{OL} = 5\text{ mA}$		0.13	0.3	
	$I_{OL} = 3.2\text{ mA}$		0.08	0.3	
$I_{DD}$ Supply current	See Note 2		170	350	$\mu\text{A}$

NOTE 2: These values apply for the expected operating configurations in which THRES is connected directly to DISCH or TRIG.



TYPICAL CHARACTERISTICS

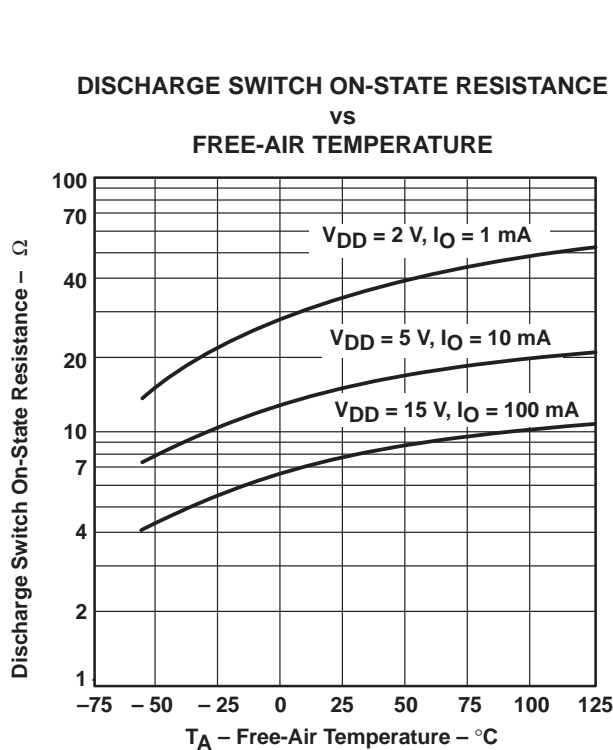
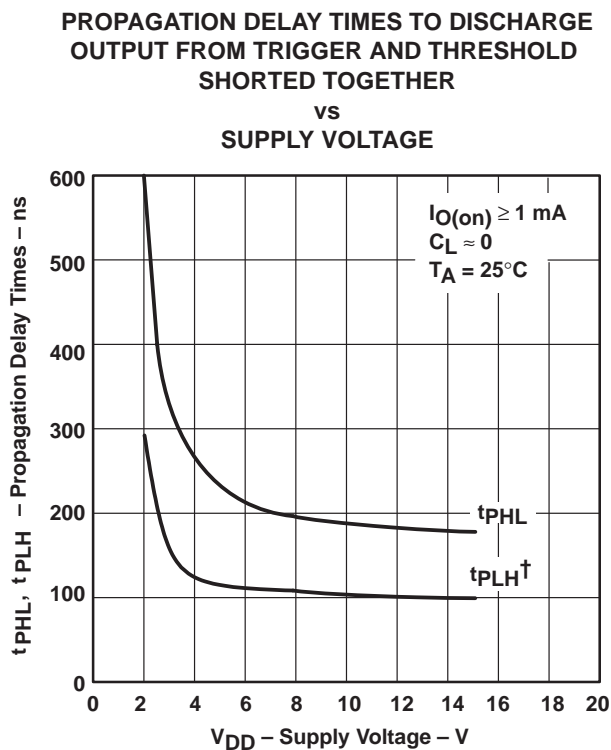

Figure 1



† The effects of the load resistance on these values must be taken into account separately.

Figure 2

APPLICATION INFORMATION

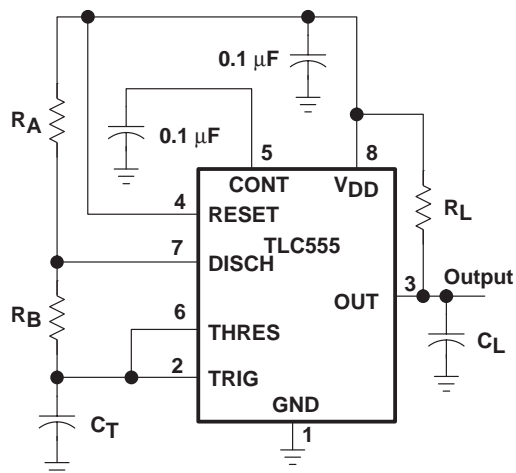

Pin numbers shown are for all packages except the FK package.

CIRCUIT

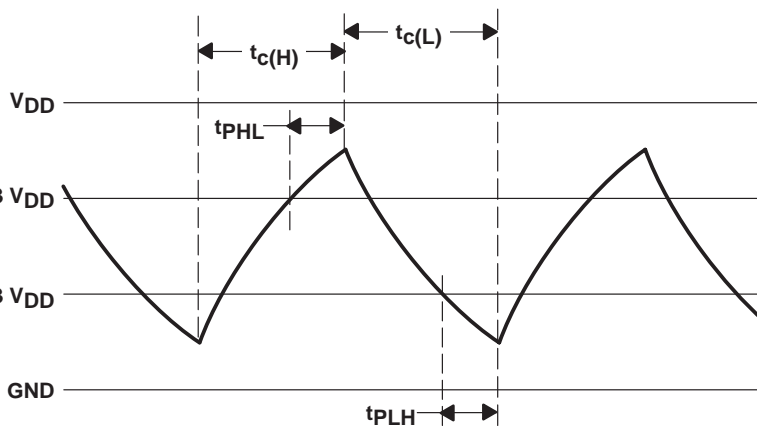

TRIGGER AND THRESHOLD VOLTAGE WAVEFORM

Figure 3. Astable Operation

**APPLICATION INFORMATION**

Connecting TRIG to THRES, as shown in Figure 3, causes the timer to run as a multivibrator. The capacitor  $C_T$  charges through  $R_A$  and  $R_B$  to the threshold voltage level (approximately  $0.67 V_{DD}$ ) and then discharges through  $R_B$  only to the value of the trigger voltage level (approximately  $0.33 V_{DD}$ ). The output is high during the charging cycle ( $t_{c(H)}$ ) and low during the discharge cycle ( $t_{c(L)}$ ). The duty cycle is controlled by the values of  $R_A$ ,  $R_B$ , and  $C_T$  as shown in the equations below.

$$t_{c(H)} \approx C_T (R_A + R_B) \ln 2 \quad (\ln 2 = 0.693)$$

$$t_{c(L)} \approx C_T R_B \ln 2$$

$$\text{Period} = t_{c(H)} + t_{c(L)} \approx C_T (R_A + 2R_B) \ln 2$$

$$\text{Output driver duty cycle} = \frac{t_{c(L)}}{t_{c(H)} + t_{c(L)}} \approx 1 - \frac{R_B}{R_A + 2R_B}$$

$$\text{Output waveform duty cycle} = \frac{t_{c(H)}}{t_{c(H)} + t_{c(L)}} \approx \frac{R_B}{R_A + 2R_B}$$

The 0.1- $\mu\text{F}$  capacitor at CONT in Figure 3 decreases the period by about 10%.

The formulas shown above do not allow for any propagation delay times from the TRIG and THRES inputs to DISCH. These delay times add directly to the period and create differences between calculated and actual values that increase with frequency. In addition, the internal on-state resistance  $r_{on}$  during discharge adds to  $R_B$  to provide another source of timing error in the calculation when  $R_B$  is very low or  $r_{on}$  is very high.

The equations below provide better agreement with measured values.

$$t_{c(H)} = C_T (R_A + R_B) \ln \left[ 3 - \exp \left( \frac{-t_{PLH}}{C_T (R_B + r_{on})} \right) \right] + t_{PLH}$$

$$t_{c(L)} = C_T (R_B + r_{on}) \ln \left[ 3 - \exp \left( \frac{-t_{PHL}}{C_T (R_A + R_B)} \right) \right] + t_{PHL}$$

These equations and those given earlier are similar in that a time constant is multiplied by the logarithm of a number or function. The limit values of the logarithmic terms must be between  $\ln 2$  at low frequencies and  $\ln 3$  at extremely high frequencies. For a duty cycle close to 50%, an appropriate constant for the logarithmic terms can be substituted

with good results. Duty cycles less than 50%  $\frac{t_{c(H)}}{t_{c(H)} + t_{c(L)}}$  require that  $\frac{t_{c(H)}}{t_{c(L)}} < 1$  and possibly  $R_A \leq r_{on}$ . These

conditions can be difficult to obtain.

In monostable applications, the trip point on TRIG can be set by a voltage applied to CONT. An input voltage between 10% and 80% of the supply voltage from a resistor divider with at least 500- $\mu\text{A}$  bias provides good results.

MECHANICAL DATA

D (R-PDSO-G\*\*)

PLASTIC SMALL-OUTLINE PACKAGE

14 PIN SHOWN

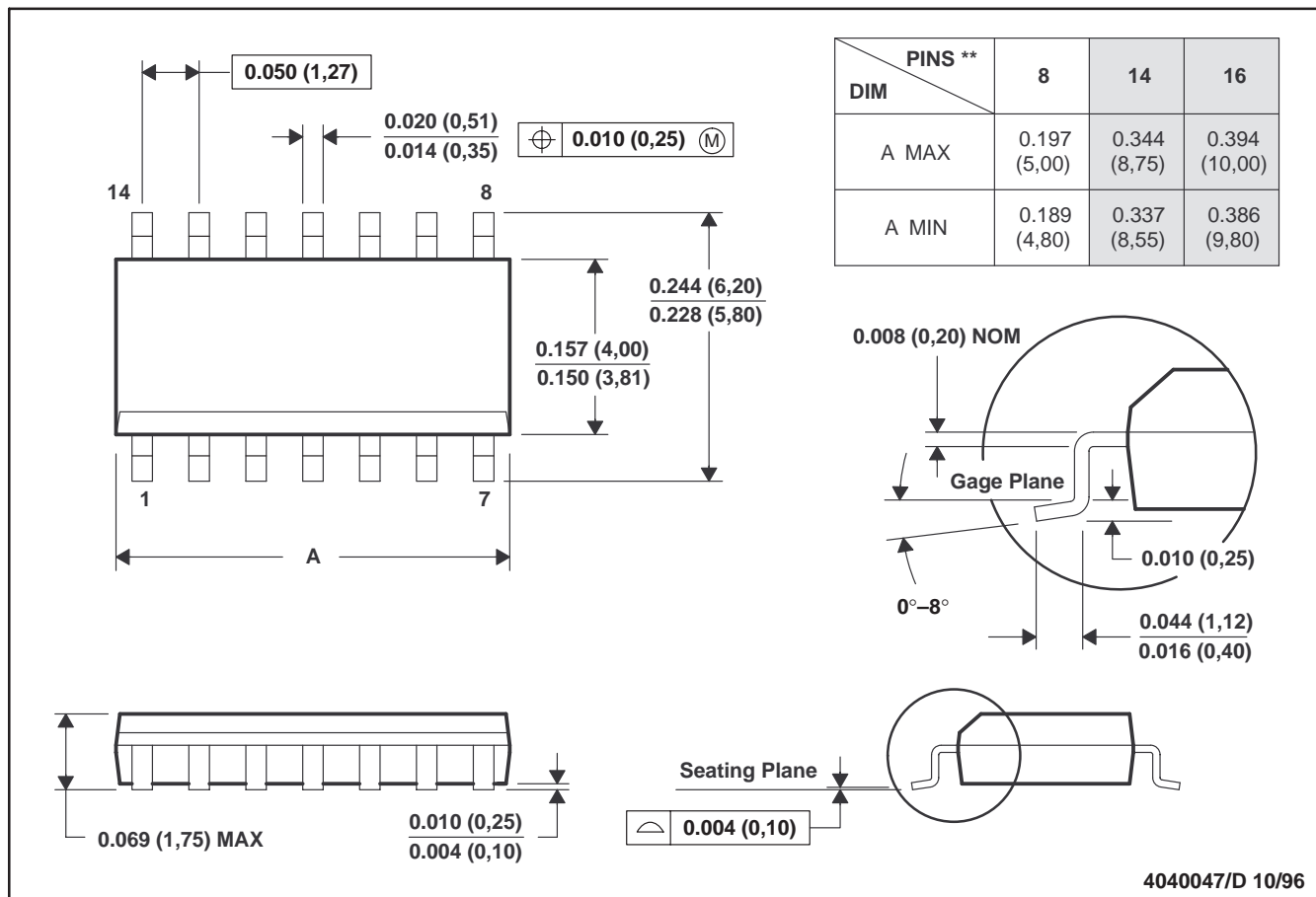

- NOTES: A. All linear dimensions are in inches (millimeters).  
 B. This drawing is subject to change without notice.  
 C. Body dimensions do not include mold flash or protrusion, not to exceed 0.006 (0,15).  
 D. Falls within JEDEC MS-012

**MECHANICAL INFORMATION**

**DB (R-PDSO-G\*\*)**

**PLASTIC SMALL-OUTLINE PACKAGE**

28 PIN SHOWN

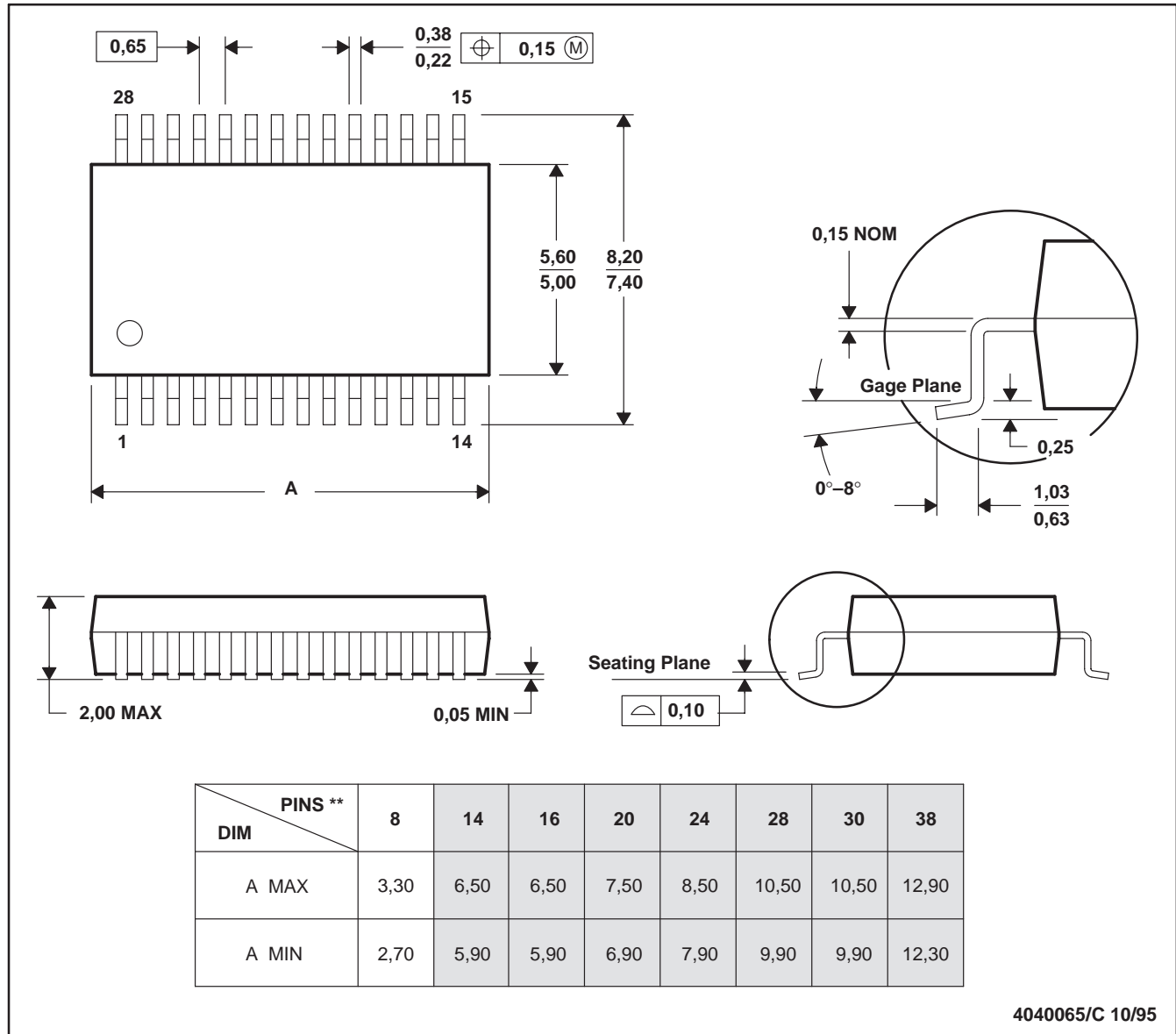

- NOTES: A. All linear dimensions are in millimeters.  
 B. This drawing is subject to change without notice.  
 C. Body dimensions do not include mold flash or protrusion not to exceed 0,15.  
 D. Falls within JEDEC MO-150

MECHANICAL INFORMATION

FK (S-CQCC-N\*\*)

LEADLESS CERAMIC CHIP CARRIER

28 TERMINAL SHOWN

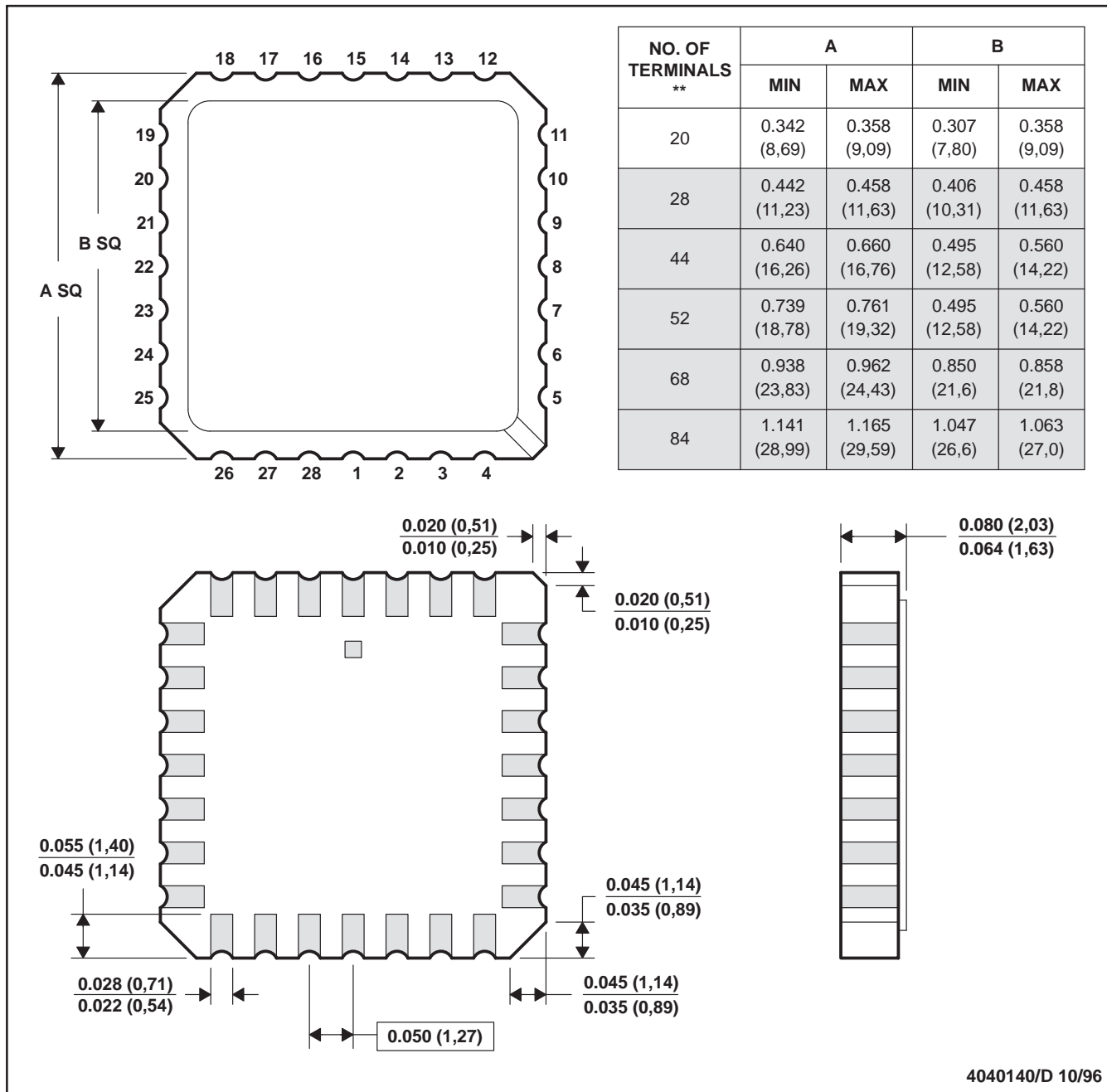

4040140/D 10/96

- NOTES:
- A. All linear dimensions are in inches (millimeters).
  - B. This drawing is subject to change without notice.
  - C. This package can be hermetically sealed with a metal lid.
  - D. The terminals are gold plated.
  - E. Falls within JEDEC MS-004

**MECHANICAL INFORMATION**

**JG (R-GDIP-T8)**

**CERAMIC DUAL-IN-LINE PACKAGE**

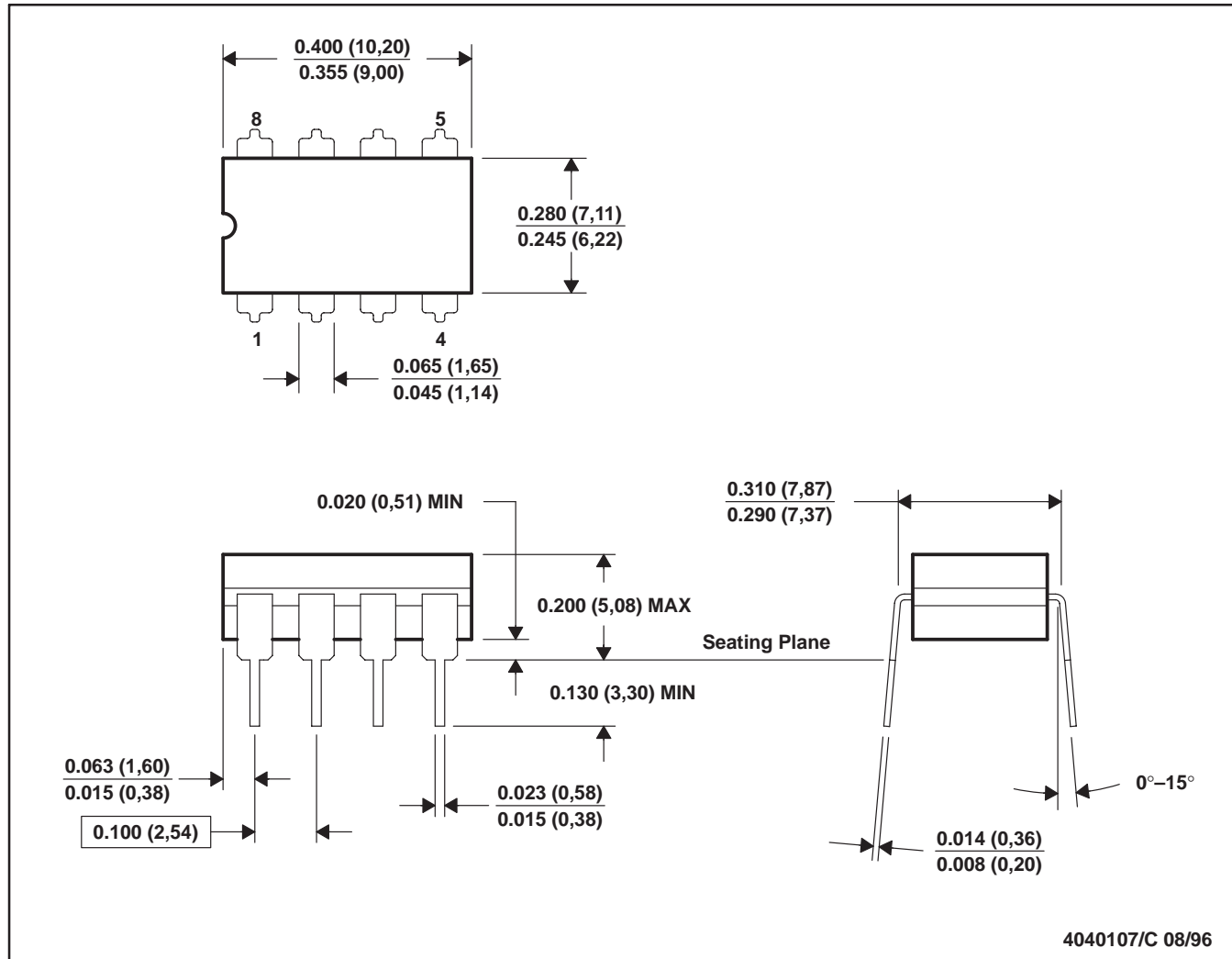

4040107/C 08/96

- NOTES: A. All linear dimensions are in inches (millimeters).  
 B. This drawing is subject to change without notice.  
 C. This package can be hermetically sealed with a ceramic lid using glass frit.  
 D. Index point is provided on cap for terminal identification only on press ceramic glass frit seal only.  
 E. Falls within MIL-STD-1835 GDIP1-T8

**MECHANICAL DATA**

**P (R-PDIP-T8)**

**PLASTIC DUAL-IN-LINE PACKAGE**

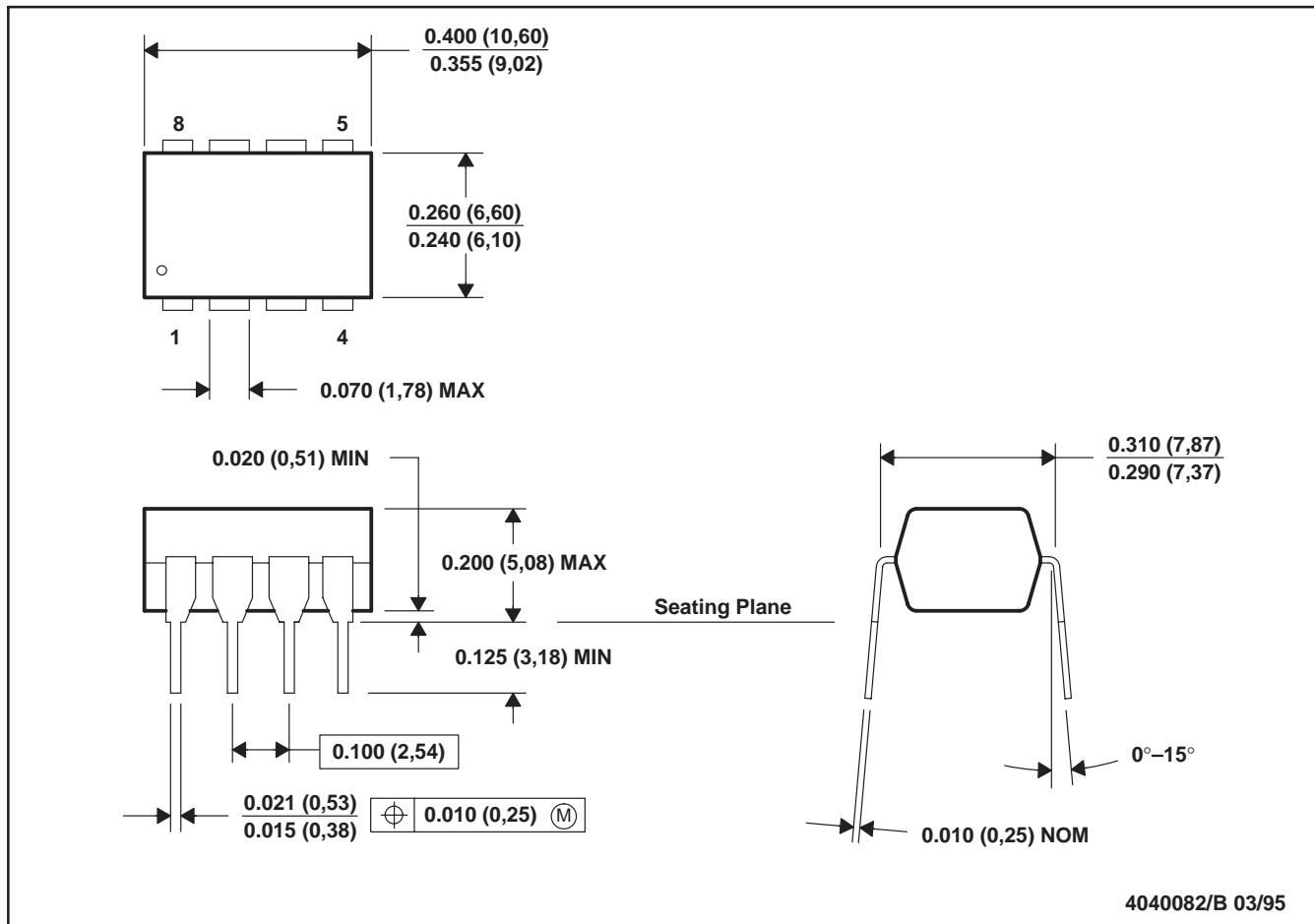

- NOTES: A. All linear dimensions are in inches (millimeters).  
B. This drawing is subject to change without notice.  
C. Falls within JEDEC MS-001

**MECHANICAL INFORMATION**

**PW (R-PDSO-G\*\*)**

**PLASTIC SMALL-OUTLINE PACKAGE**

14 PIN SHOWN

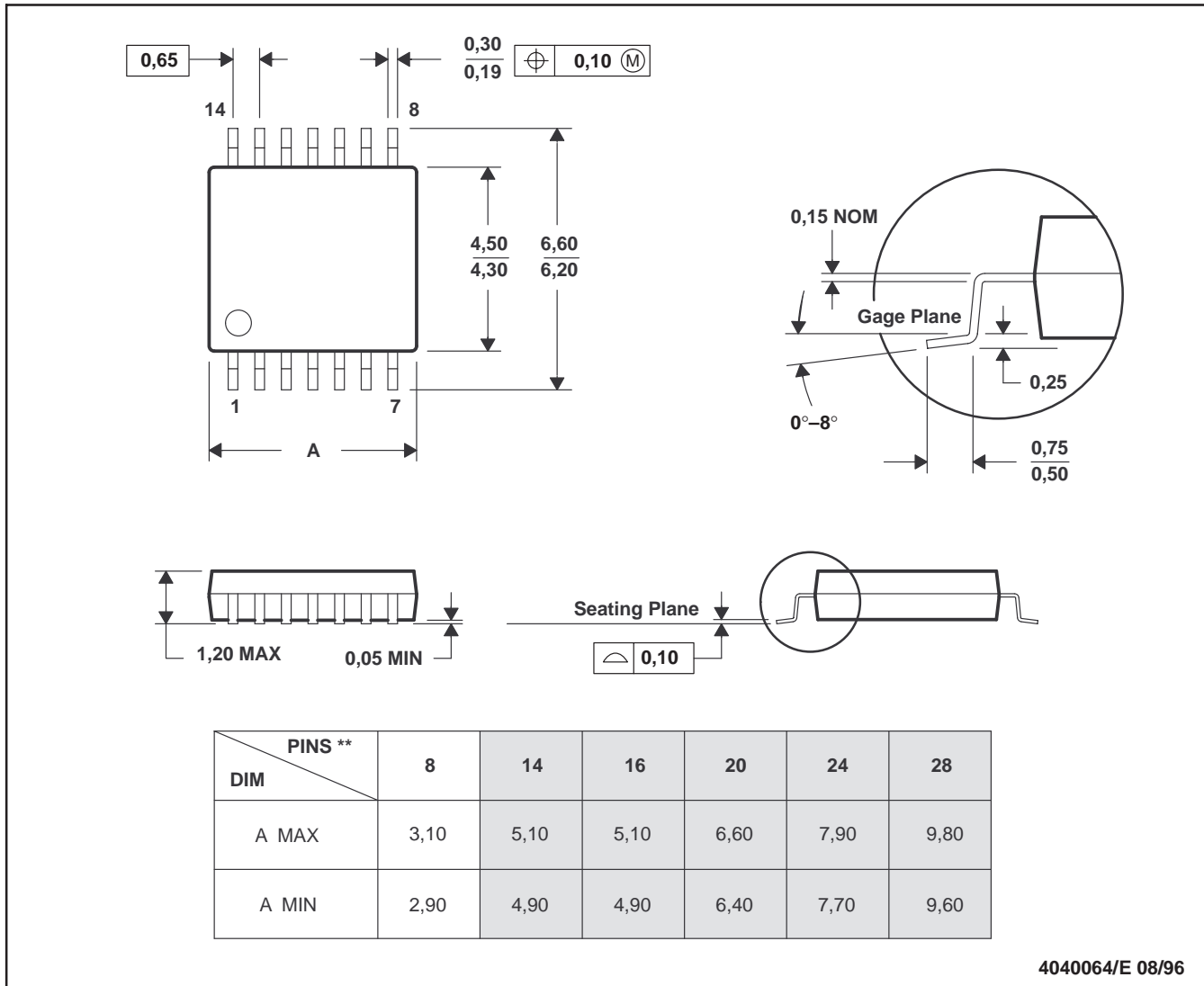

4040064/E 08/96

- NOTES: A. All linear dimensions are in millimeters.  
 B. This drawing is subject to change without notice.  
 C. Body dimensions do not include mold flash or protrusion not to exceed 0,15.  
 D. Falls within JEDEC MO-153



## **IMPORTANT NOTICE**

Texas Instruments and its subsidiaries (TI) reserve the right to make changes to their products or to discontinue any product or service without notice, and advise customers to obtain the latest version of relevant information to verify, before placing orders, that information being relied on is current and complete. All products are sold subject to the terms and conditions of sale supplied at the time of order acknowledgment, including those pertaining to warranty, patent infringement, and limitation of liability.

TI warrants performance of its semiconductor products to the specifications applicable at the time of sale in accordance with TI's standard warranty. Testing and other quality control techniques are utilized to the extent TI deems necessary to support this warranty. Specific testing of all parameters of each device is not necessarily performed, except those mandated by government requirements.

Customers are responsible for their applications using TI components.

In order to minimize risks associated with the customer's applications, adequate design and operating safeguards must be provided by the customer to minimize inherent or procedural hazards.

TI assumes no liability for applications assistance or customer product design. TI does not warrant or represent that any license, either express or implied, is granted under any patent right, copyright, mask work right, or other intellectual property right of TI covering or relating to any combination, machine, or process in which such semiconductor products or services might be or are used. TI's publication of information regarding any third party's products or services does not constitute TI's approval, warranty or endorsement thereof.